

THIS DOCUMENT IS THE PROPERTY OF
KEYSTONE ELECTRONICS CORP. AND
SHALL NOT BE REPRODUCED, DISTRIBUTED
OR USED AS A BASIS FOR MANUFACTURE
WITHOUT PRIOR WRITTEN PERMISSION
FROM KEYSTONE ELECTRONICS CORP.

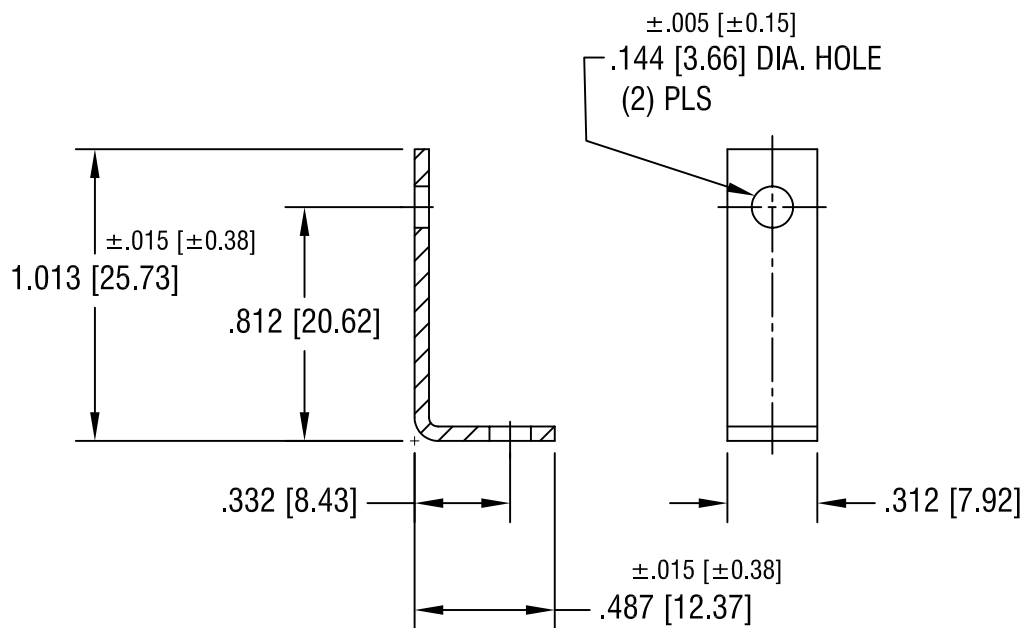

KEYSTONE ELECTRONICS CORP.			
ASTORIA, N.Y. 11105-2017			
PART NAME			
BRACKET			
MATERIAL			
.050 [1.27] TH'K STEEL			
FINISH		DRN BY	DATE
NICKEL PLATE		BOONE	8.25.98
		APPD	SCALE
			1.5X
TOLERANCES	INCH	[MM]	CODE
DECIMAL	$\pm .010$	[± 0.25]	C
ANGULAR	$\pm 1^\circ$		
UNLESS OTHERWISE SPECIFIED			
DWG NO.		4326	

9.8.04 | CHANGE AS PER ECN 04-087 | B

DATE	DESCRIPTION	REV.
------	-------------	------