

DATE	DESCRIPTION	REV.
9.23.05	CHANGE AS PER ECN 05-070	B

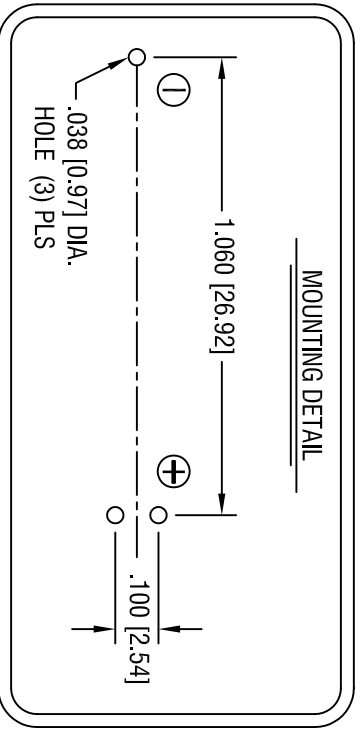
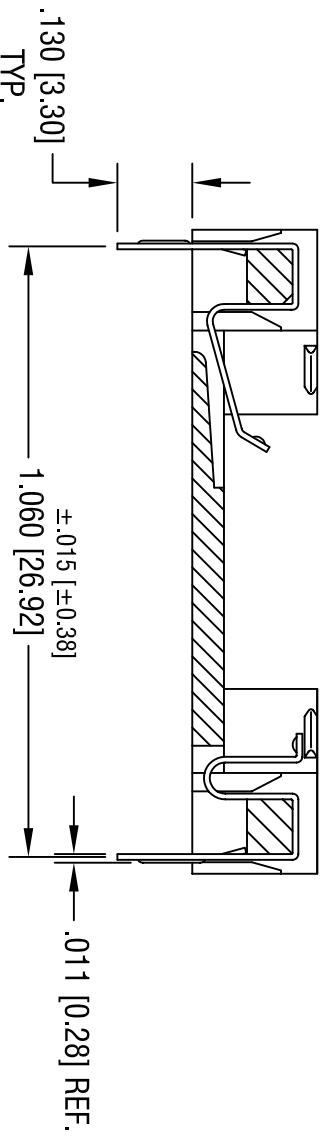
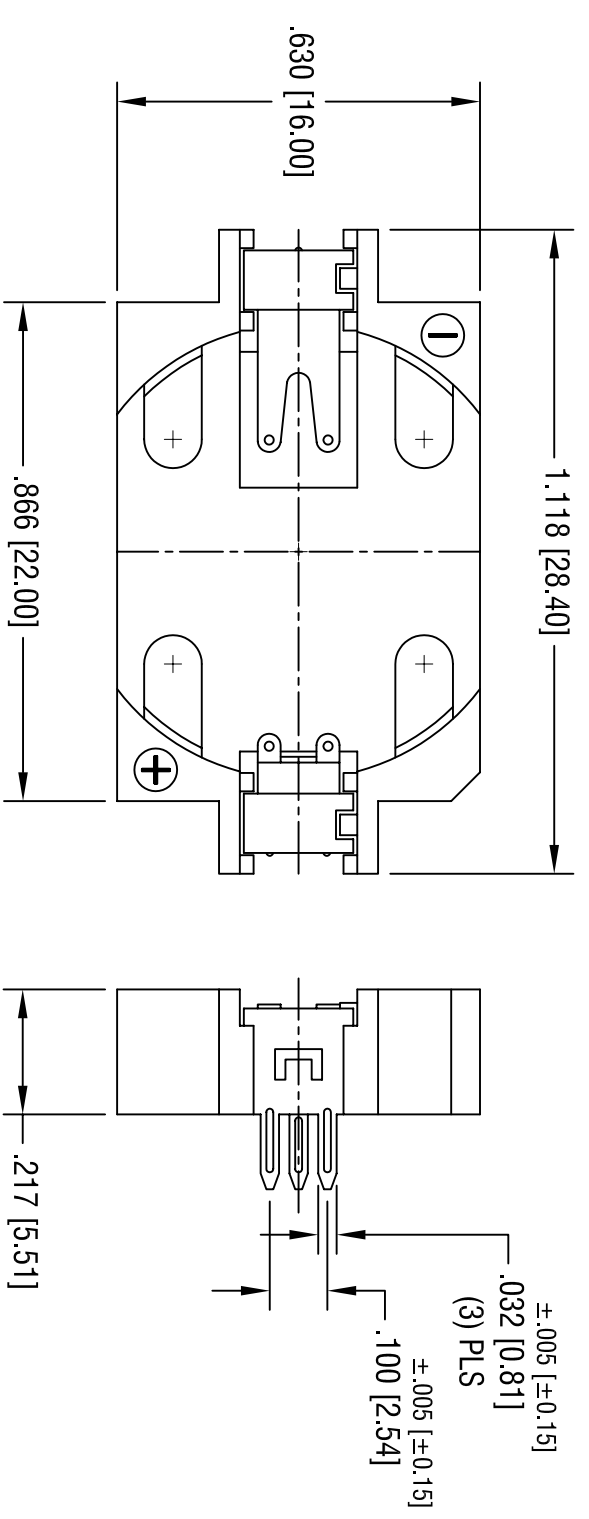

NOTES:

- 1. BASE:
MATE'L - GLASS FILLED LCP UL 94V-0
- 2. CONTACTS:
MATE'L - .006 [0.15] THK PHOSPHOR BRONZE
FINISH - TIN OVER NICKEL PLATE

KEYSTONE ELECTRONICS CORP.			
ASTORIA, N.Y. 11105-2017			
PART NAME		2032 BATTERY HOLDER, PC	
MATERIAL		AS NOTED	
FINISH	AS NOTED	DRN BY	C.W.
TOLERANCES		CODE	DWG NO.
INCH	[MM]	C	1059
DECIMAL	± .010 [± 0.25]		
ANGULAR	± 1°		
UNLESS OTHERWISE SPECIFIED			
App'd		DATE	SCALE
LN		11.29.99	3X

THIS DOCUMENT IS THE PROPERTY OF KEYSTONE ELECTRONICS CORP. AND SHALL NOT BE REPRODUCED, DISTRIBUTED OR USED AS A BASIS FOR MANUFACTURE WITHOUT PRIOR WRITTEN PERMISSION FROM KEYSTONE ELECTRONICS CORP.