

Ansicht X
View X

Real View

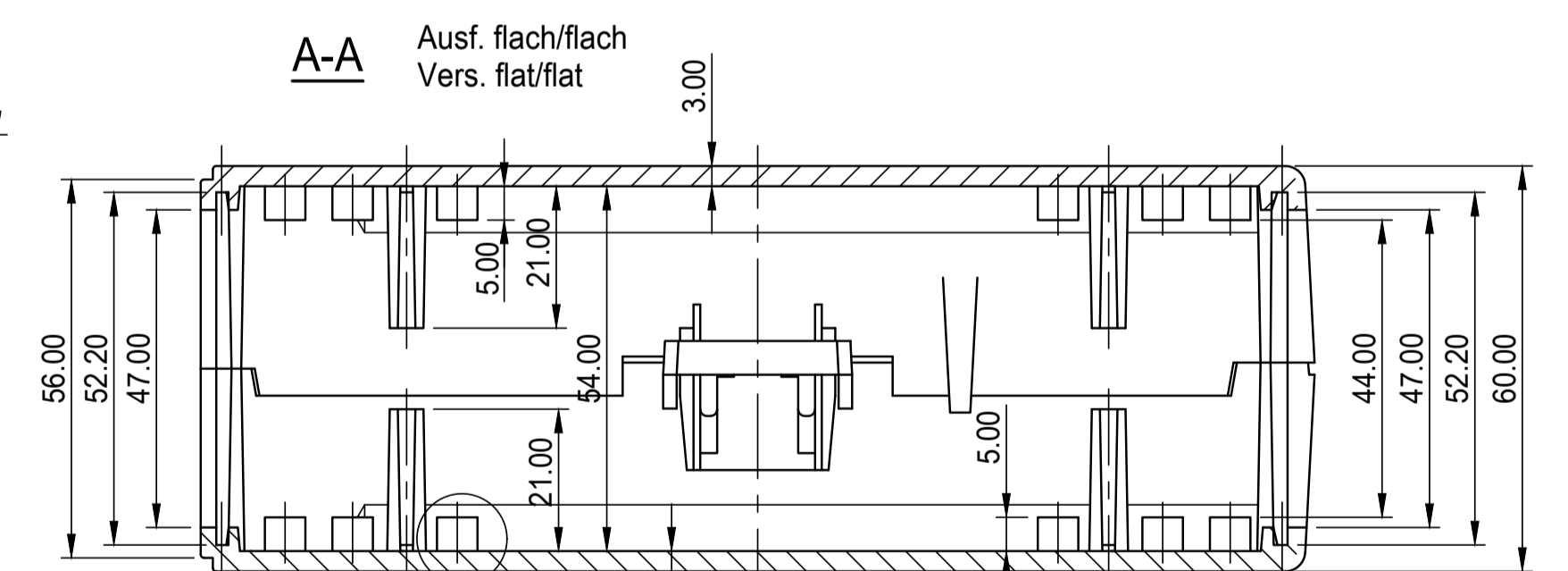
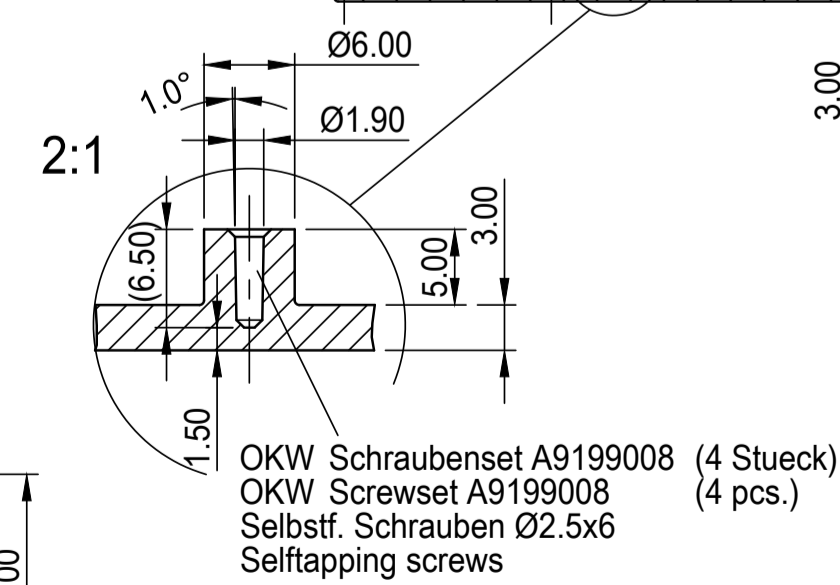
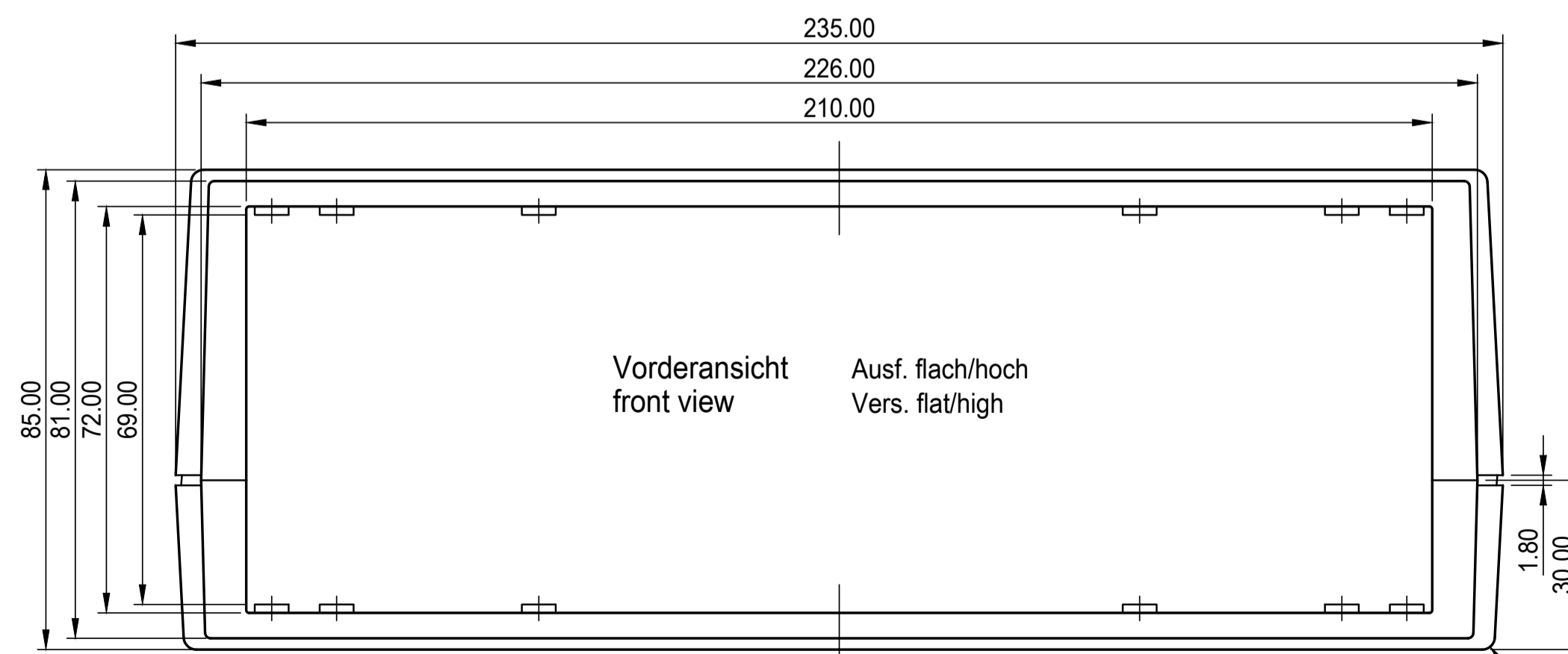
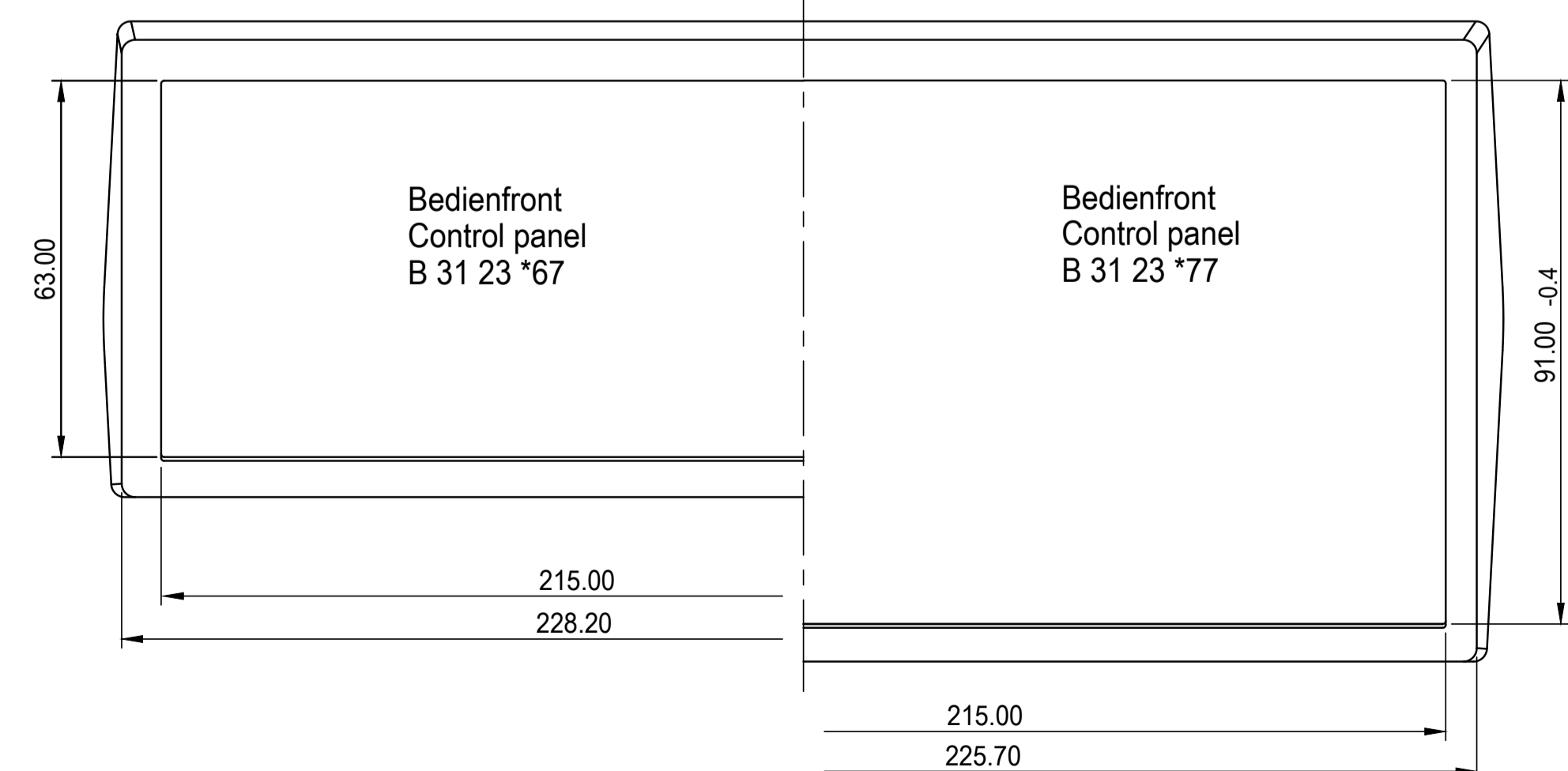

Important notice: X, Y dimension and convergence of recessed area could can vary. But cut of membrane foil must always be revolving undersized so that it match well with enclosure. Therefore, before starting serial outline cut, please check and adapt it with current samples.

max. Platinengröße: 208 x 150 mm (Domaussparung unberücksichtigt)
max. size of PCB: 208 x 150 mm (cutouts for pillars not taken into consideration)

OGB 31 23 *77	Bedienfront für hoch/hoch Kombination Control panel for high/high combination			
OGB 31 23 *67	Bedienfront für flach/hoch Kombination Control panel for flat/high combination			
OGB 30 23 *3*	235	165	110	hoch / hoch high / high
OGB 30 23 *2*	235	165	85	flach / hoch flat / high
OGB 30 23 *1*	235	165	60	flach / flach flat / flat
Bestell-Nr. Order No.	L	B	H	Kombination combination
	L	W	H	

Informationskopie wird nicht aktualisiert	Copy for Information will not be updated	Erst. am: 21.10.1993 Erst. von: Hassab Freig. am: Revision: 08	Toleranzen: DIN 16742 TG 6 Volumen: Zeichnungsart: KUNDE	Status: ÄNDERUNG Zeichnungsart: KUNDE	DIN 6 Teil 2 1:1
--	---	---	--	--	---------------------

<p>Technische Änderungen vorbehalten. Irrtümer und Druckfehler begründen keinen Anspruch auf Schadensersatz. Wichtige Einbaumaße bitte direkt mit dem aktuellen Produkt abstimmen. Subject to technical modification without prior notice. Typographical and other errors do not justify any claim for damages. All dimensions should be verified using an actual moulded part. Sous réserve de modifications techniques. Toute erreur ou faute d'impression ne justifie aucune demande d'indemnisation. Nous prions les clients de vérifier les dimensions des composants avec les boîtiers avant le montage.</p>		<p>This document contains proprietary information of OKW Gehäusesysteme GmbH and is rendered subject to the conditions that the information be retained in confidence and not be reproduced or copied and not be used or incorporated in any product.</p>	<p>OKW GEHÄUSE SYSTEME</p>	<p>MOTEC L CASE, complete B3023...</p>	<p>Für dieses Dokument behalten wir uns alle Urheberrechte vor. Es darf auch auszugsweise weder vervielfältigt noch Dritten in irgendeiner Form zugänglich gemacht werden.</p>	<p>Dateiname: 00000453</p>
--	--	---	------------------------------------	--	--	--------------------------------