

Unterteil hoch, Ausf. II  
Innenansicht  
Bottom part high, vers. II  
inside view  
B 40 46 767

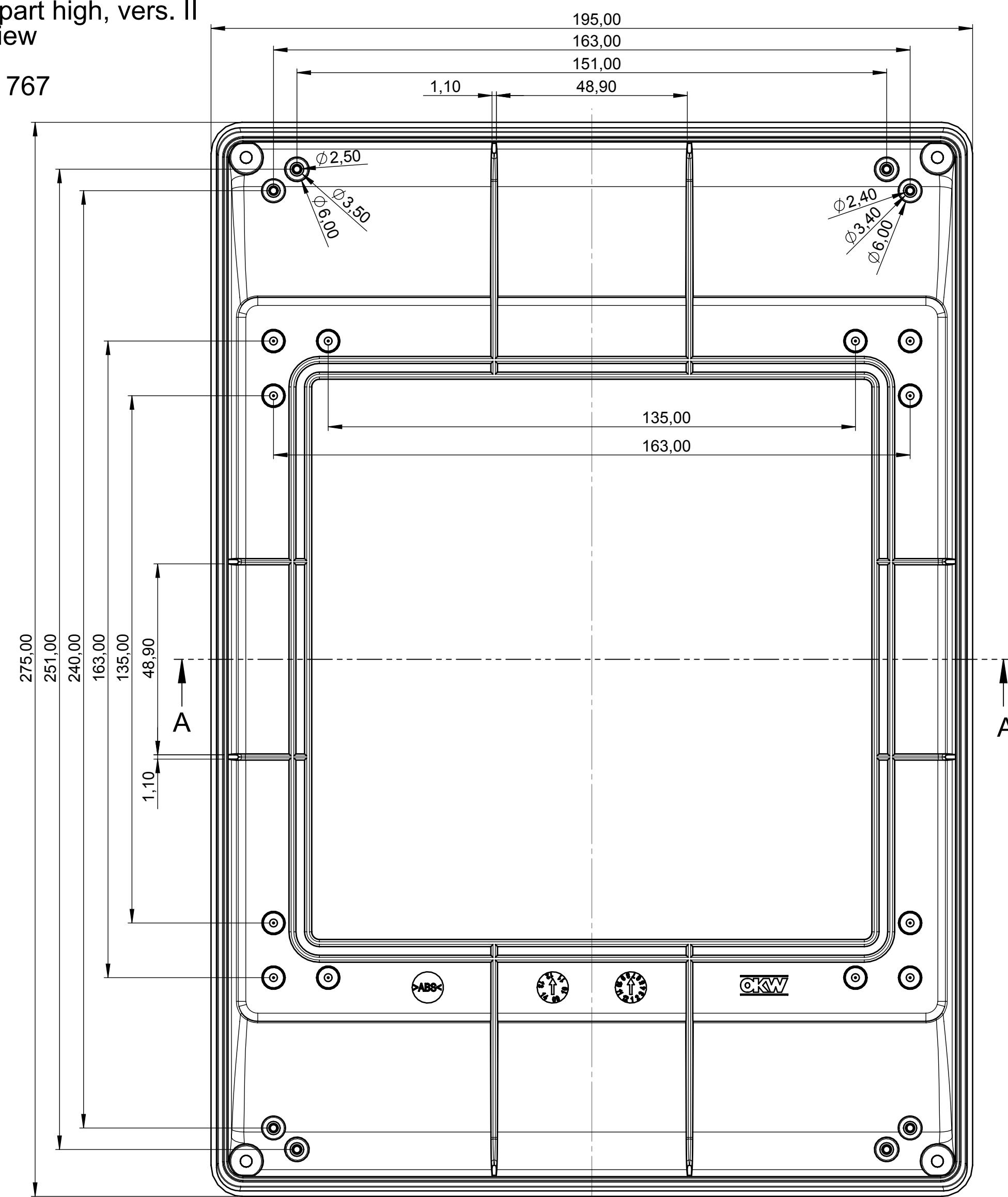

Montageplatte für Glaspanel  
Aussenansicht  
Mounting plate for glass panel  
outside view  
B 41 46 203

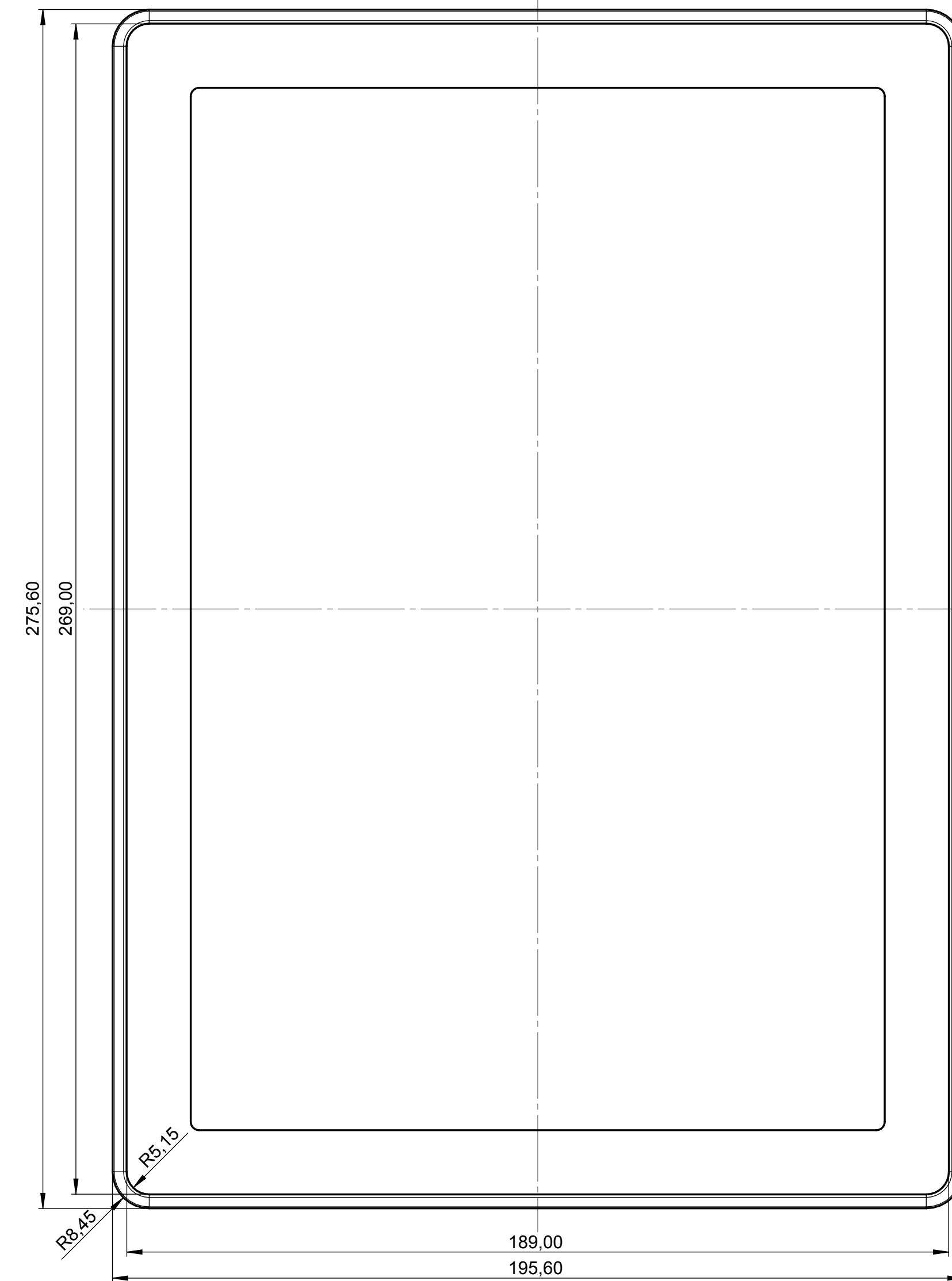

Montageplatte für Glaspanel  
Innenansicht  
Mounting plate for glass panel  
inside view  
B 41 46 203

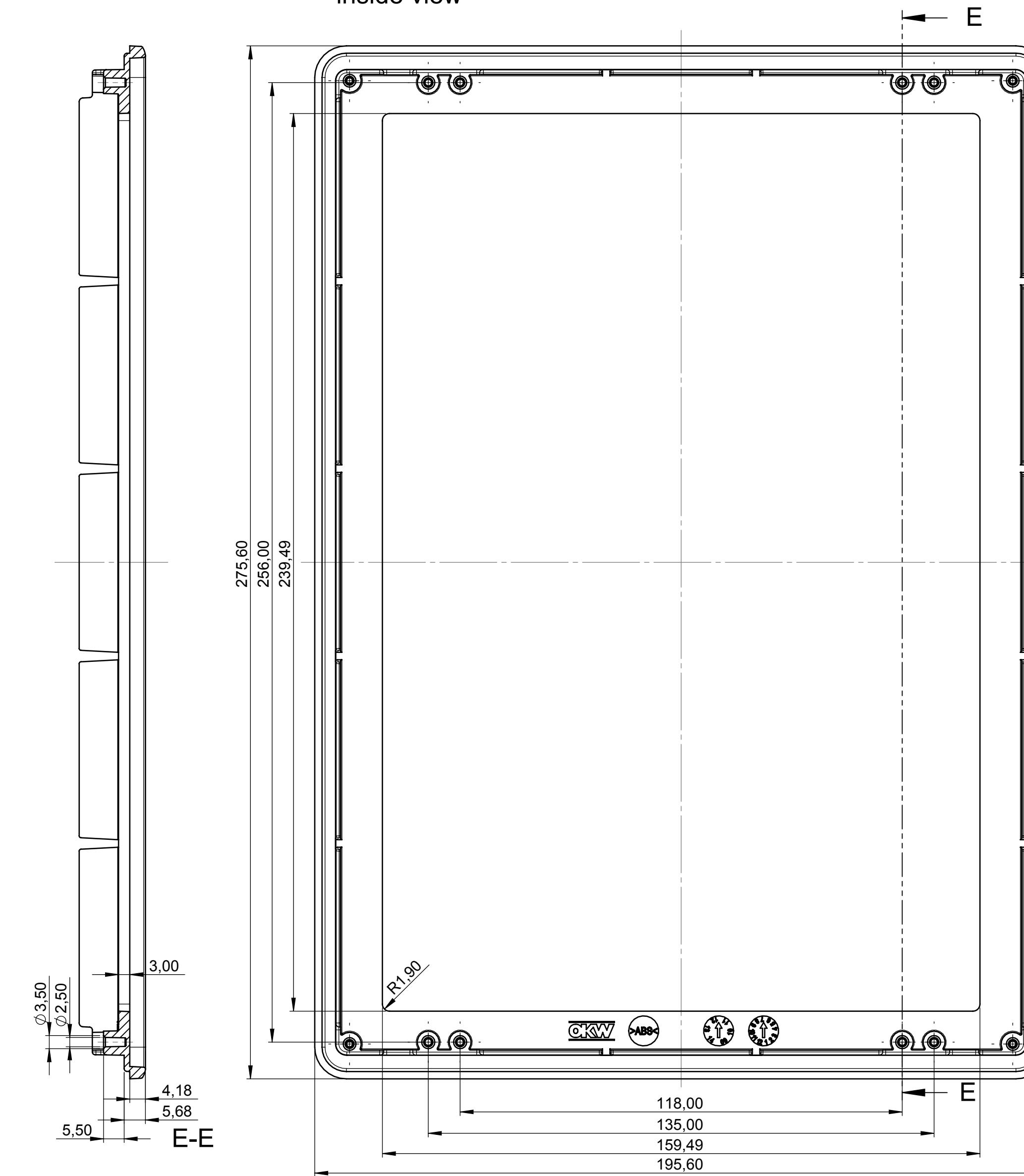

Glaspanel  
Glass panel  
B 41 46 203

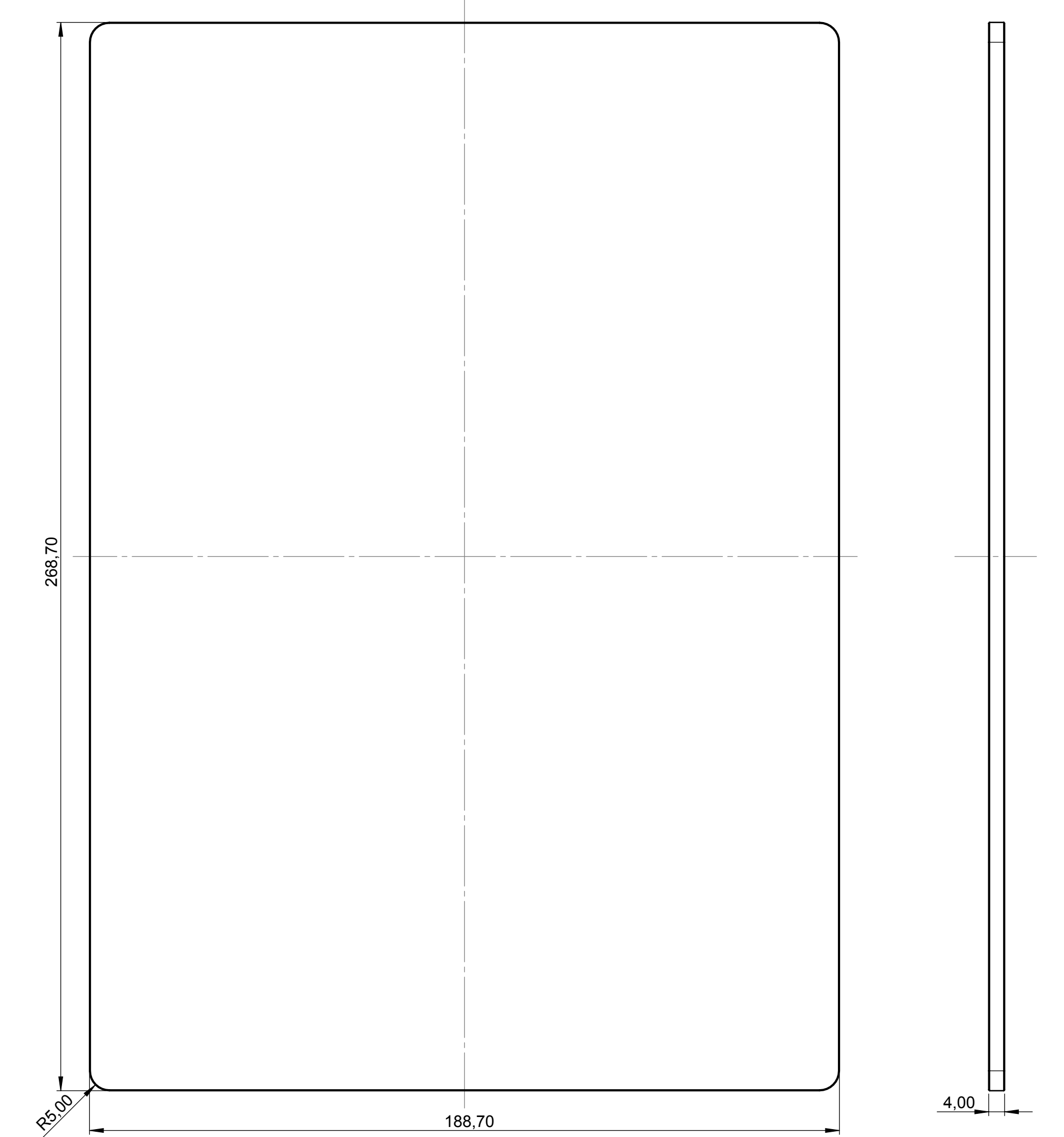

Batteriefach  
Battery compartment  
B 41 46 047

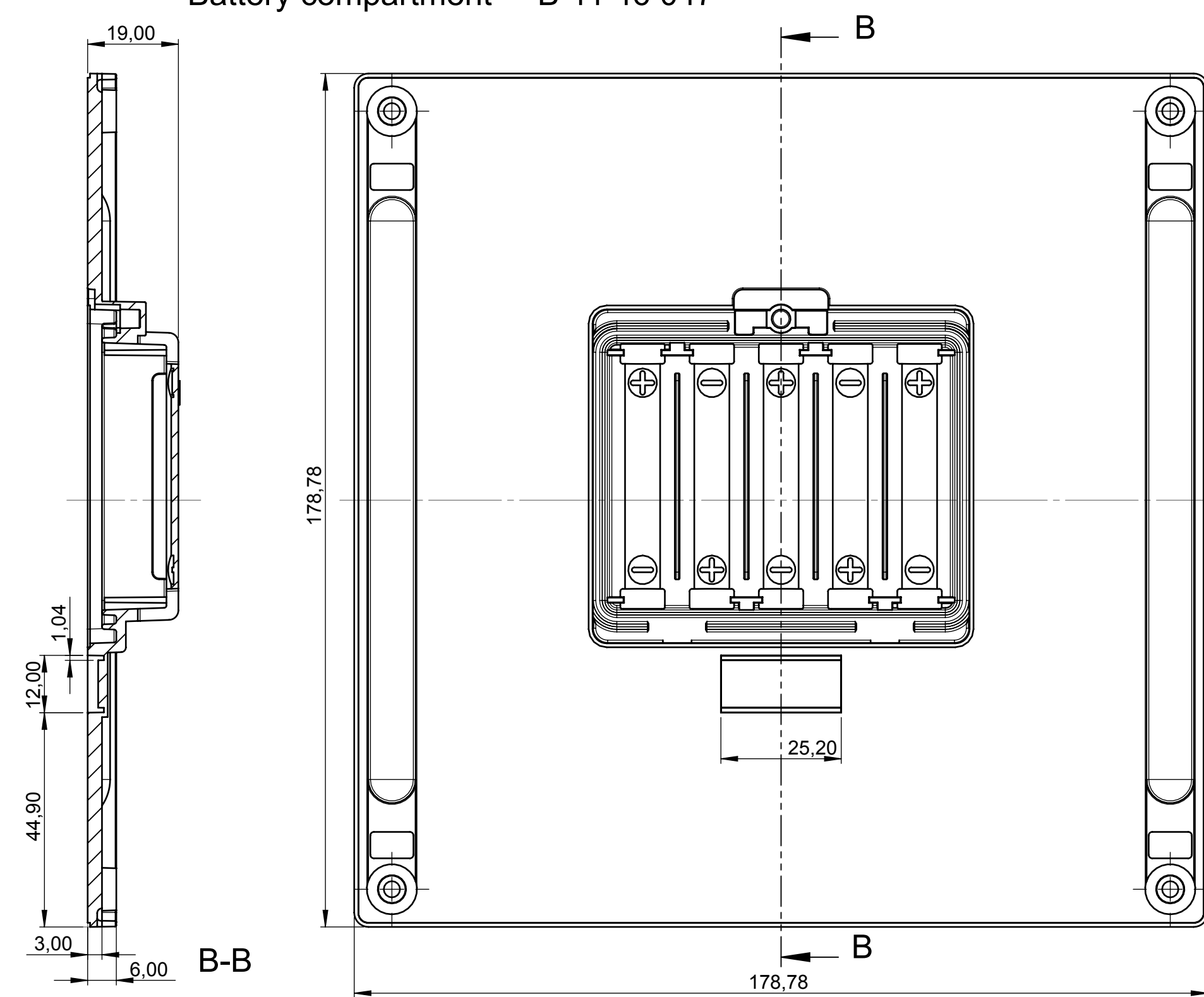

Bodenplatte mit Rastleisten  
Bottom panel with snap-in strips  
B 41 46 257

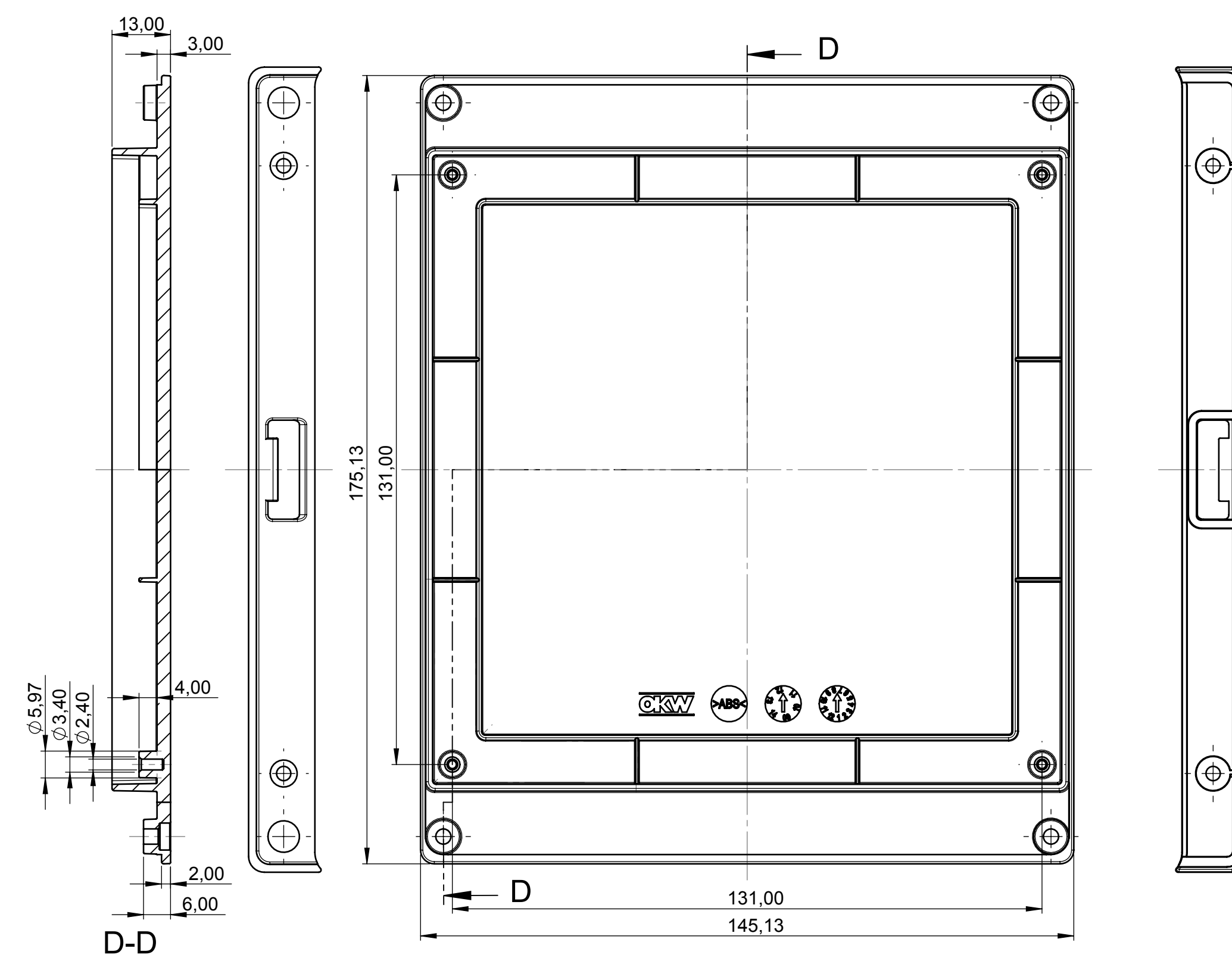

Frontplatte ABS  
Aussenansicht  
Front panel ABS  
outside view  
B 41 46 107

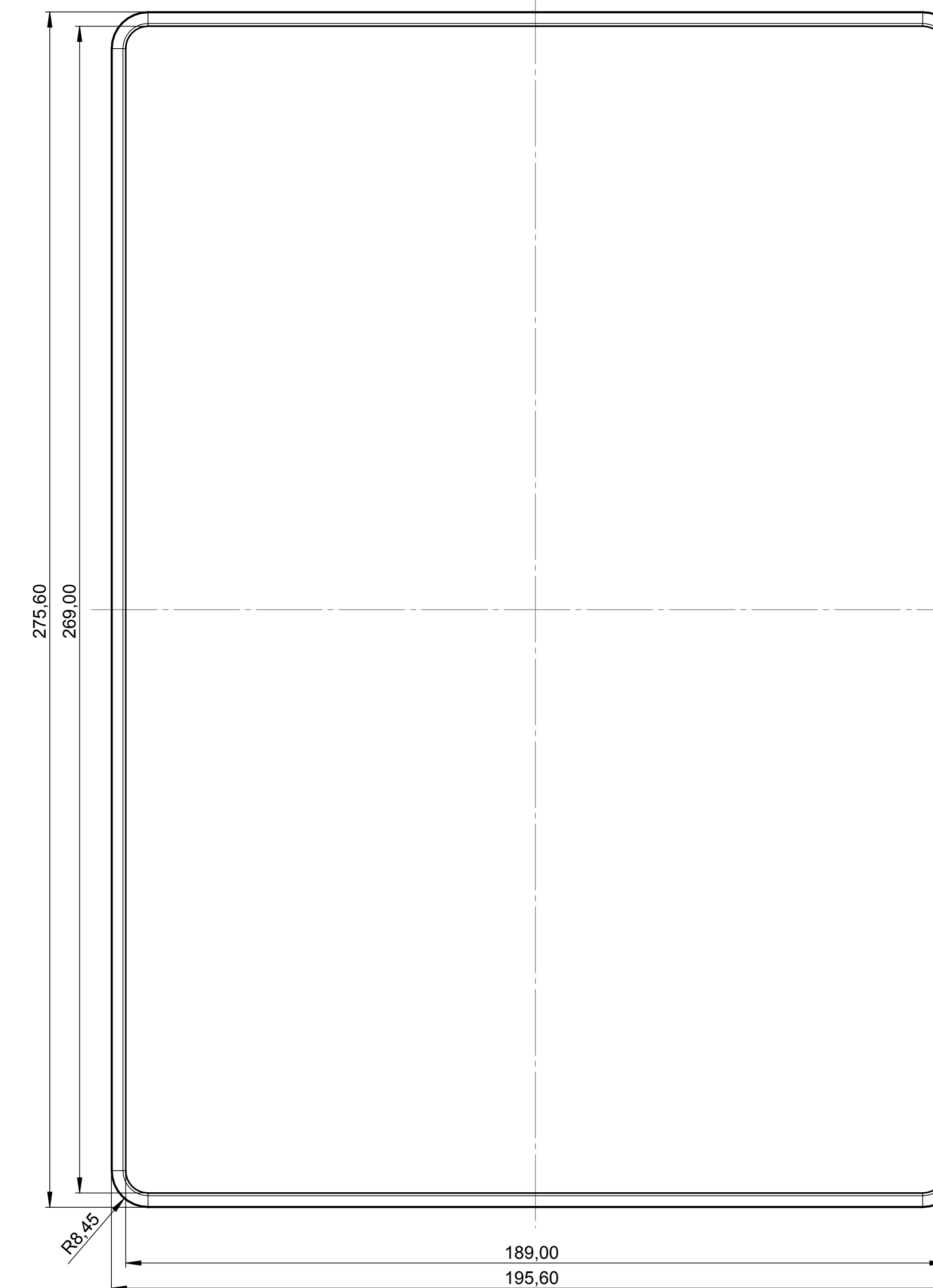

Frontplatte ABS  
Innenansicht  
Front panel ABS  
inside view  
B 41 46 107

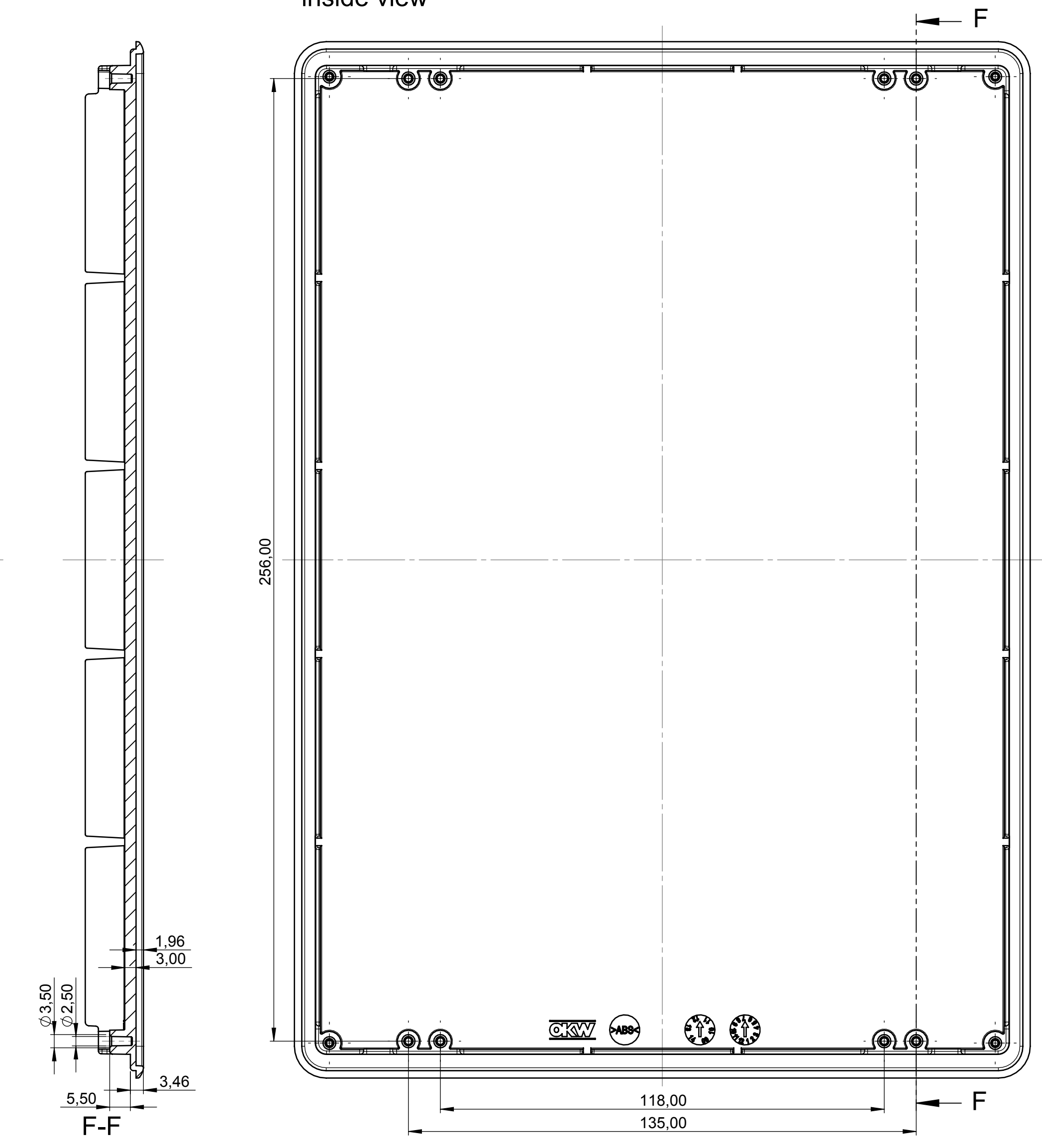

Bodenplatte mit Griffmulde  
Bottom panel with handle recess  
B 41 46 167

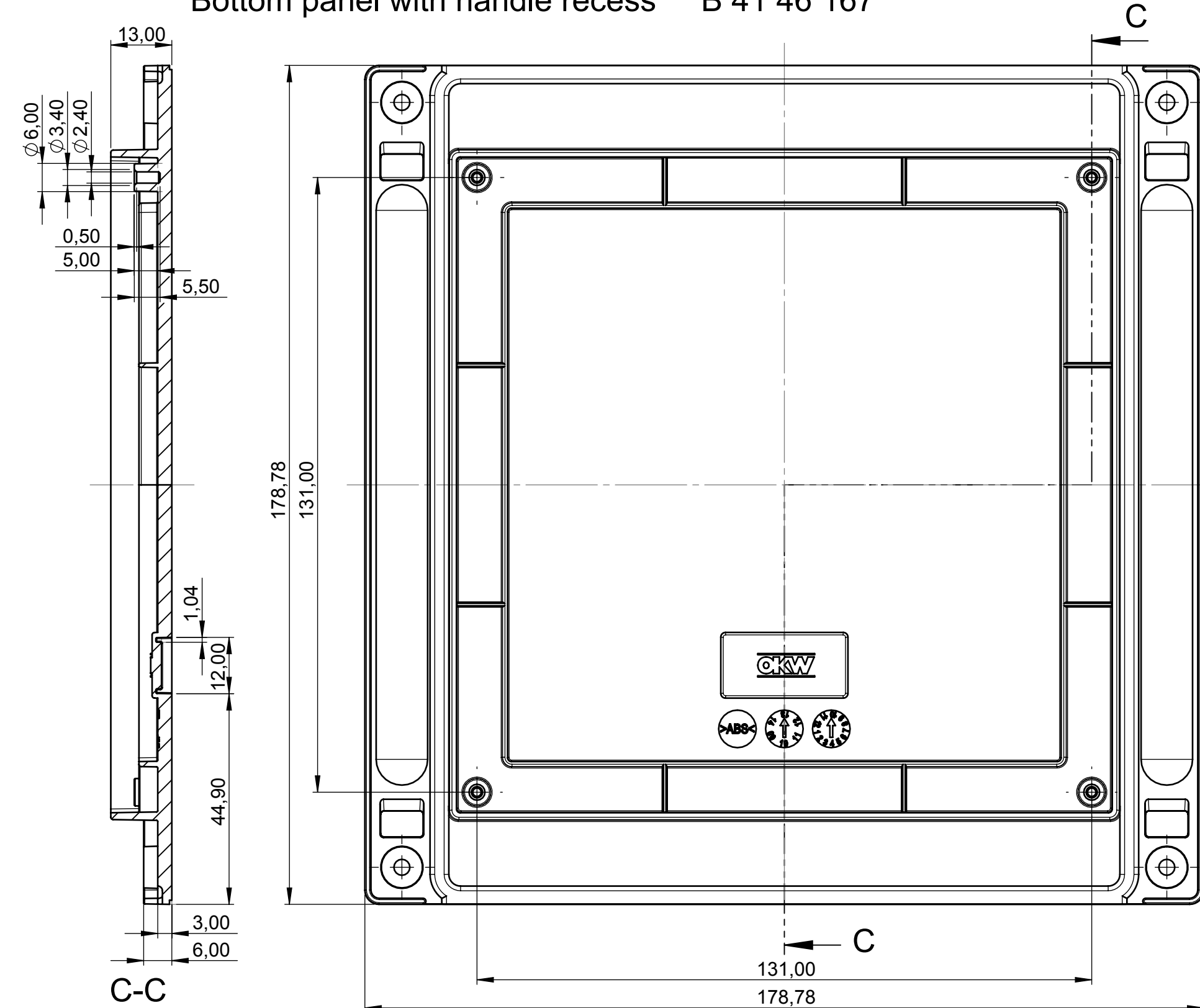

Socket  
Base B 40 46 8\*7

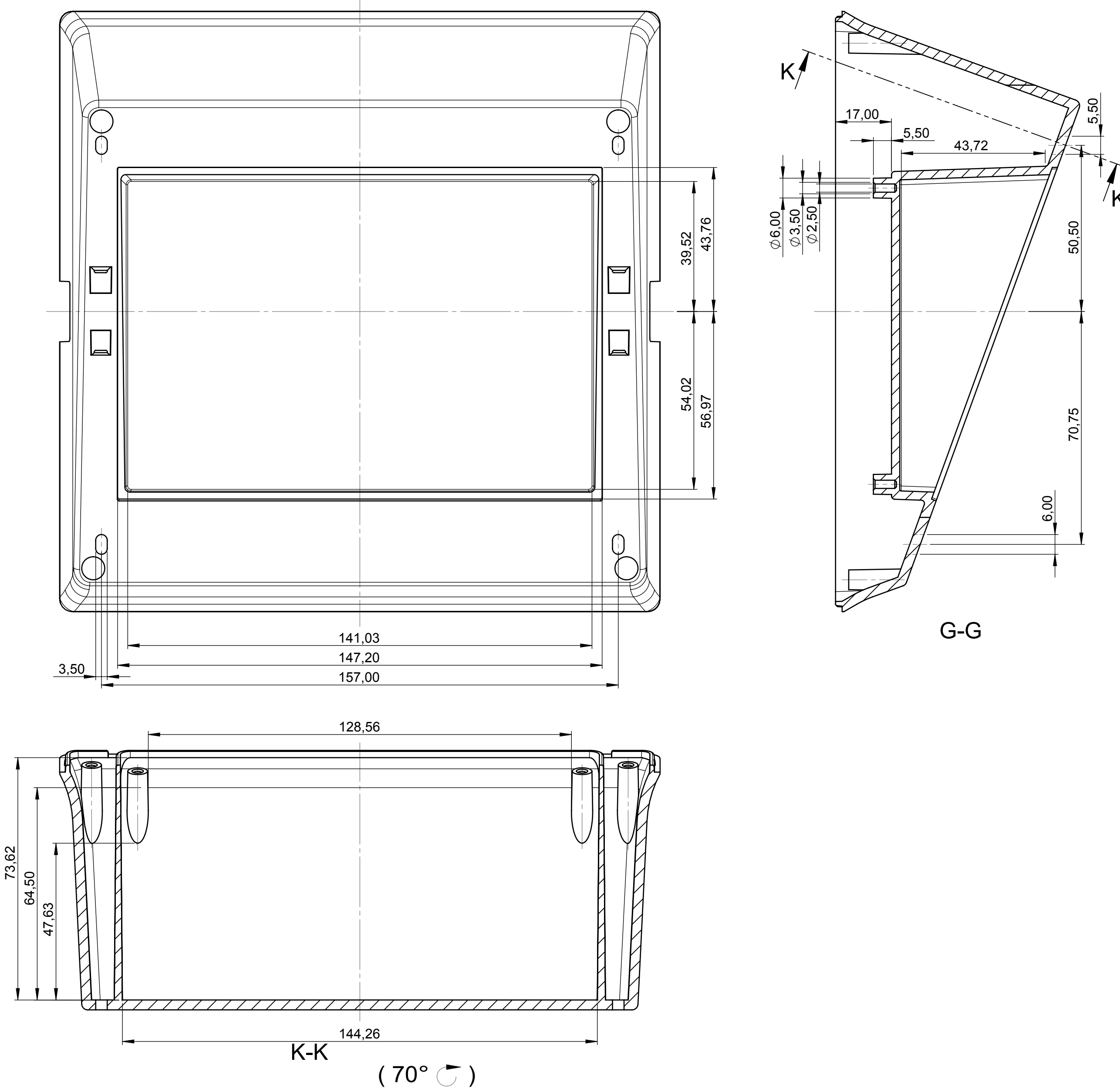

Platine Unterteil  
PCB bottom part

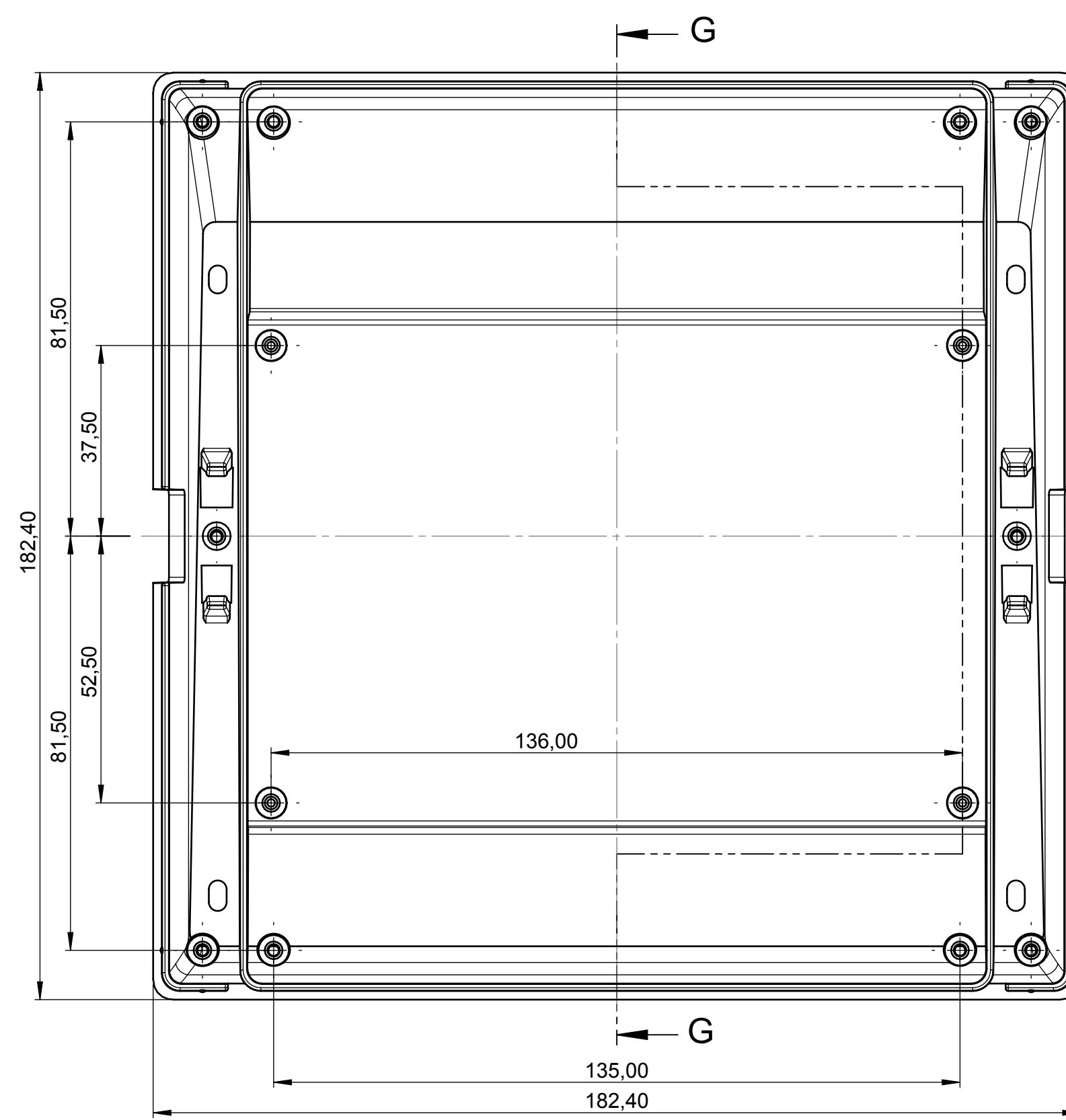

Platine Unterteil mit Batteriefach  
PCB bottom part with battery compartment

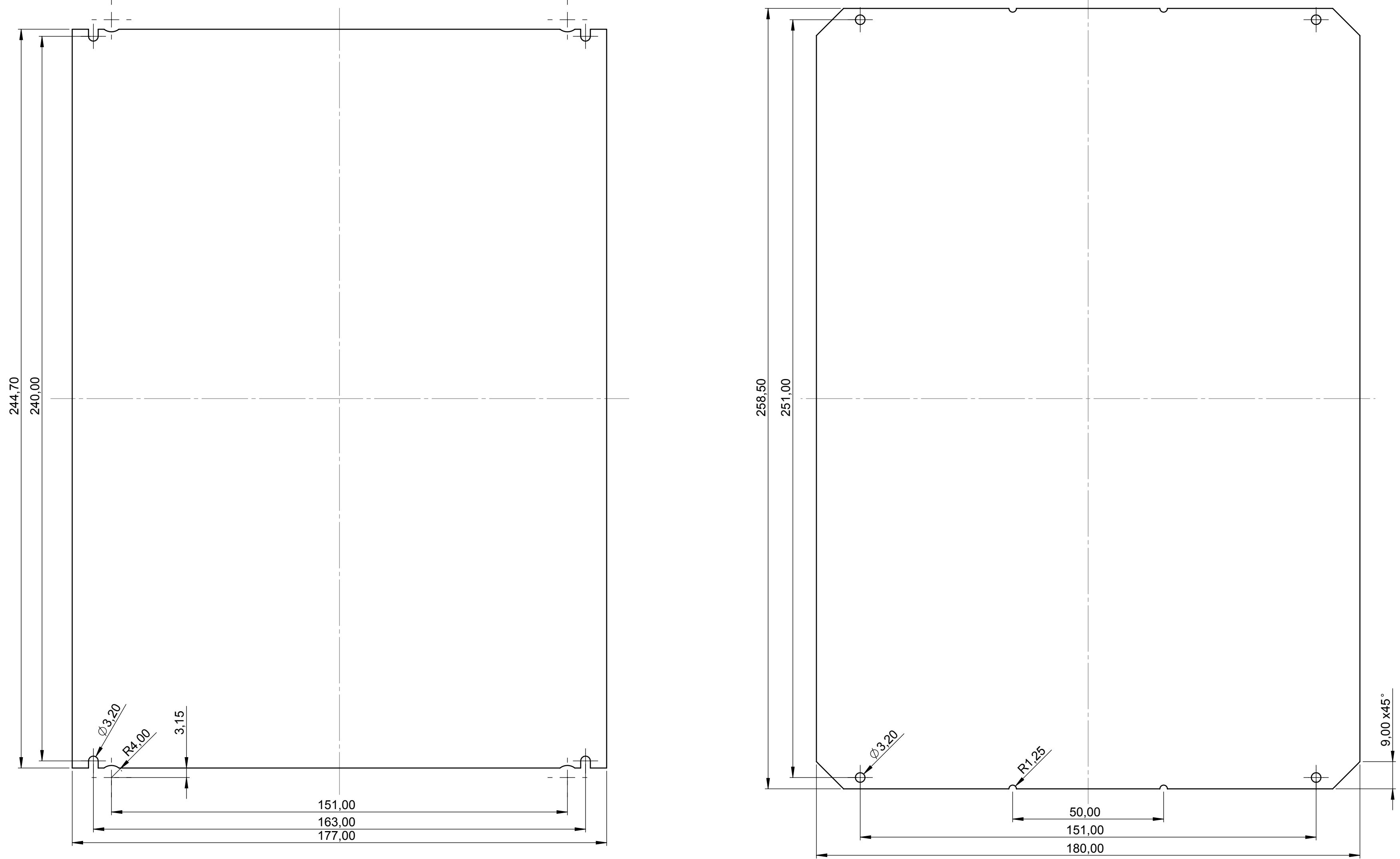

Sockeldeckel für Arretierung  
Base cover

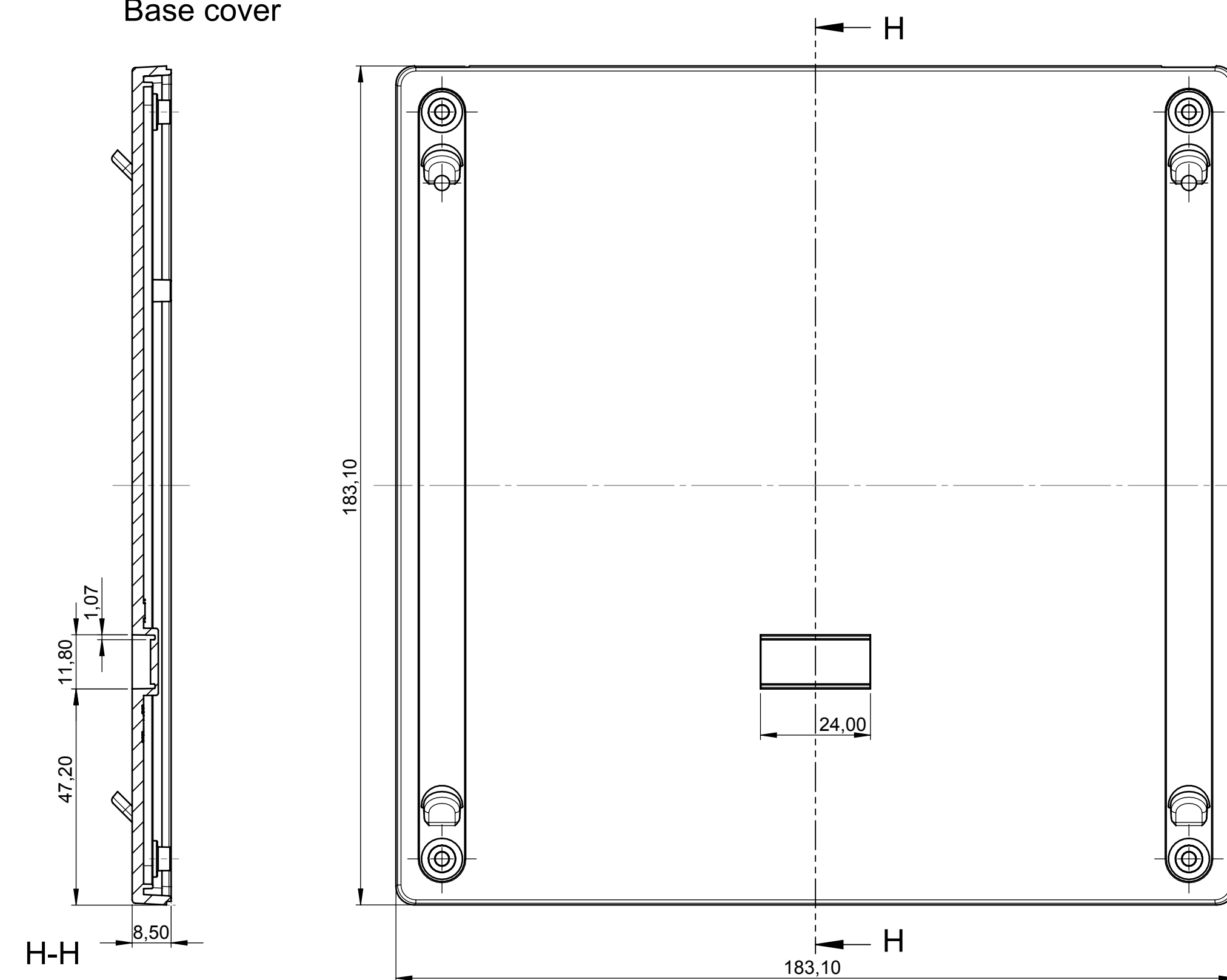

Unterteil hoch, Ausf. II  
Bottom part high, vers. II

Glaspanel, Batteriefach, Sockel  
Glass panel, battery compartment, base

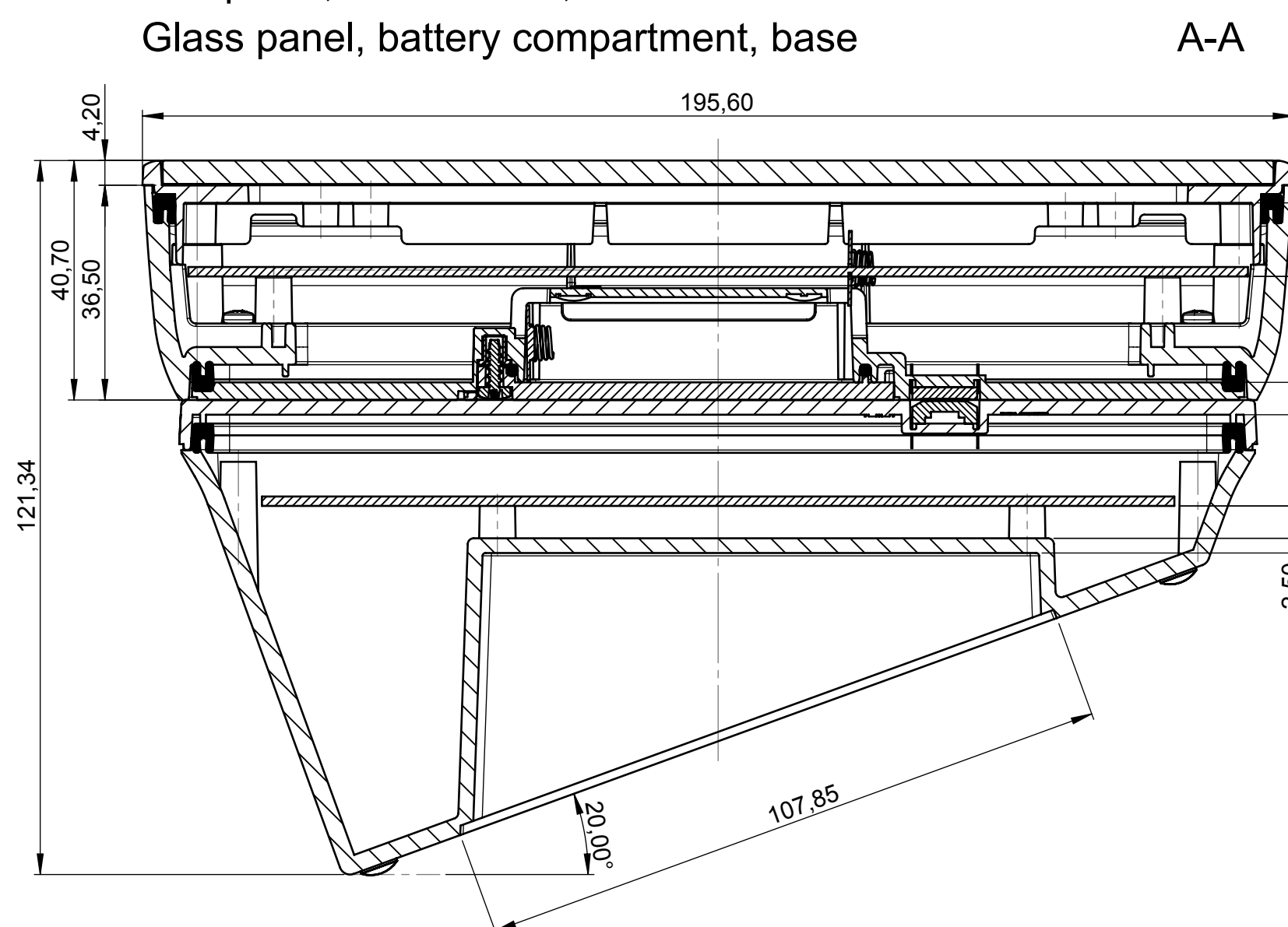

Frontplatte ABS, Batteriefach, Sockel  
Front panel ABS, battery compartment, base

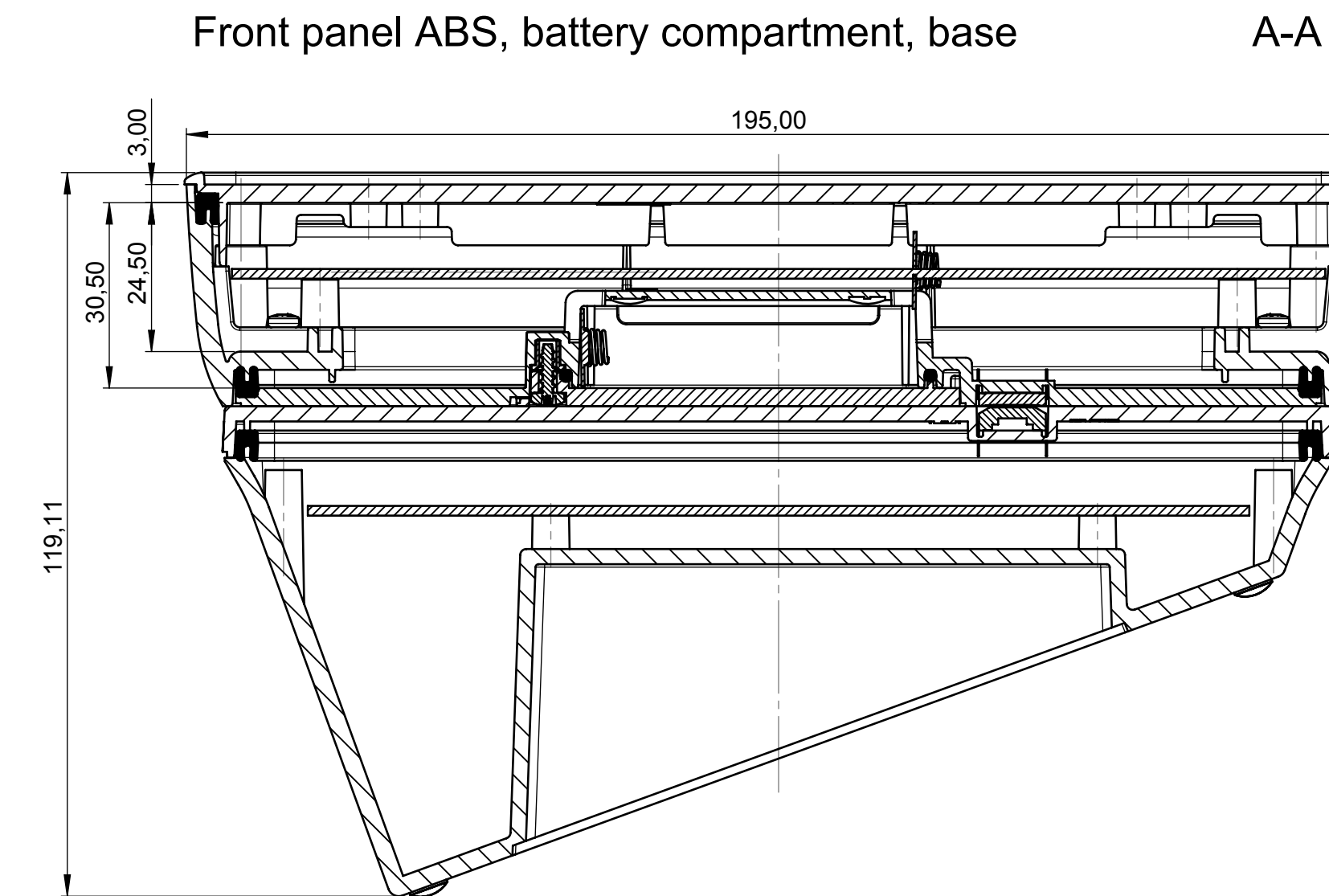

Glaspanel, Bodenplatte mit Griffmulde, Sockel  
Glass panel, bottom panel with handle recess, base

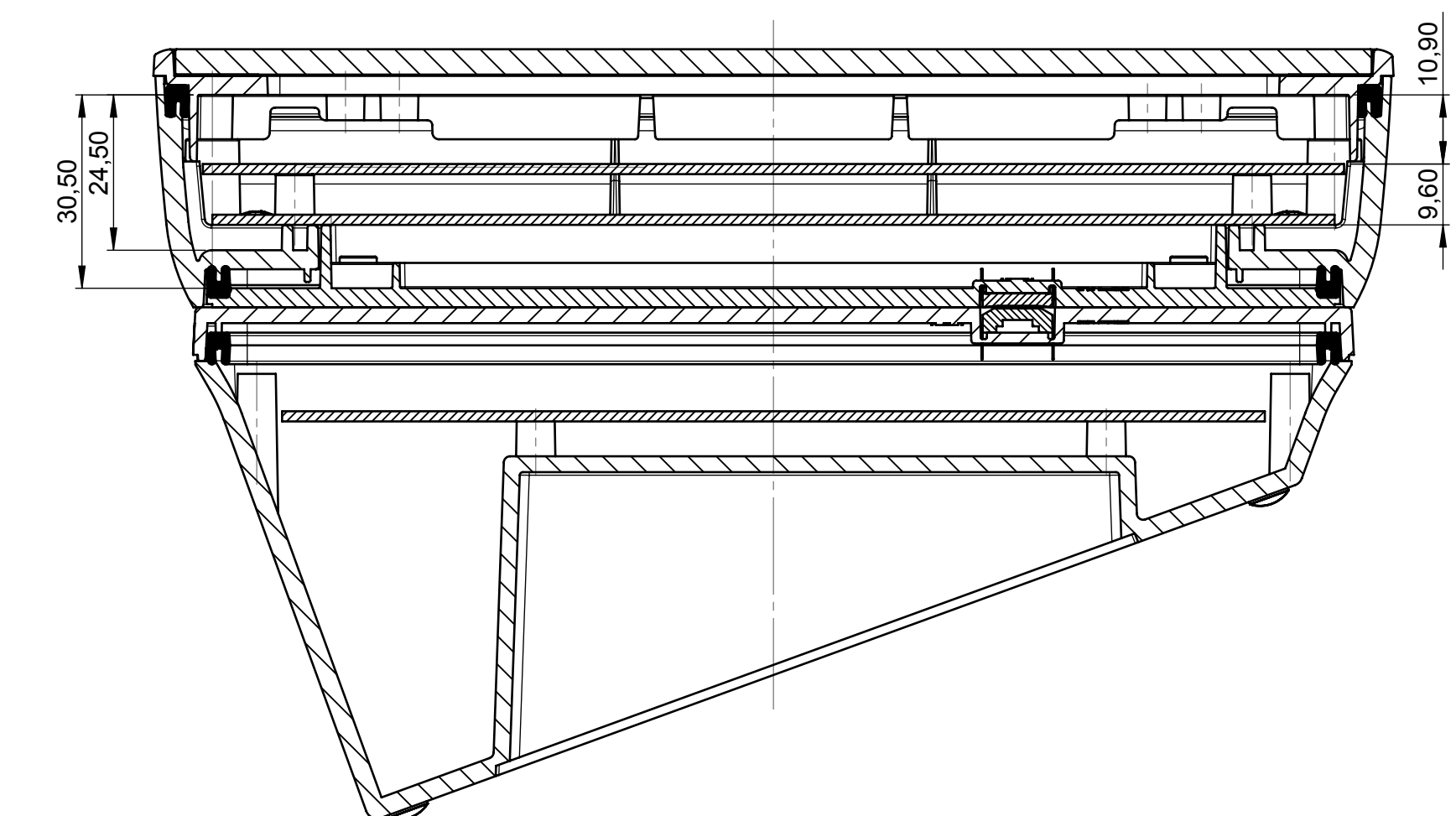

Frontplatte ABS, Bodenplatte mit Griffmulde, Sockel  
Front panel ABS, bottom panel with handle recess, base

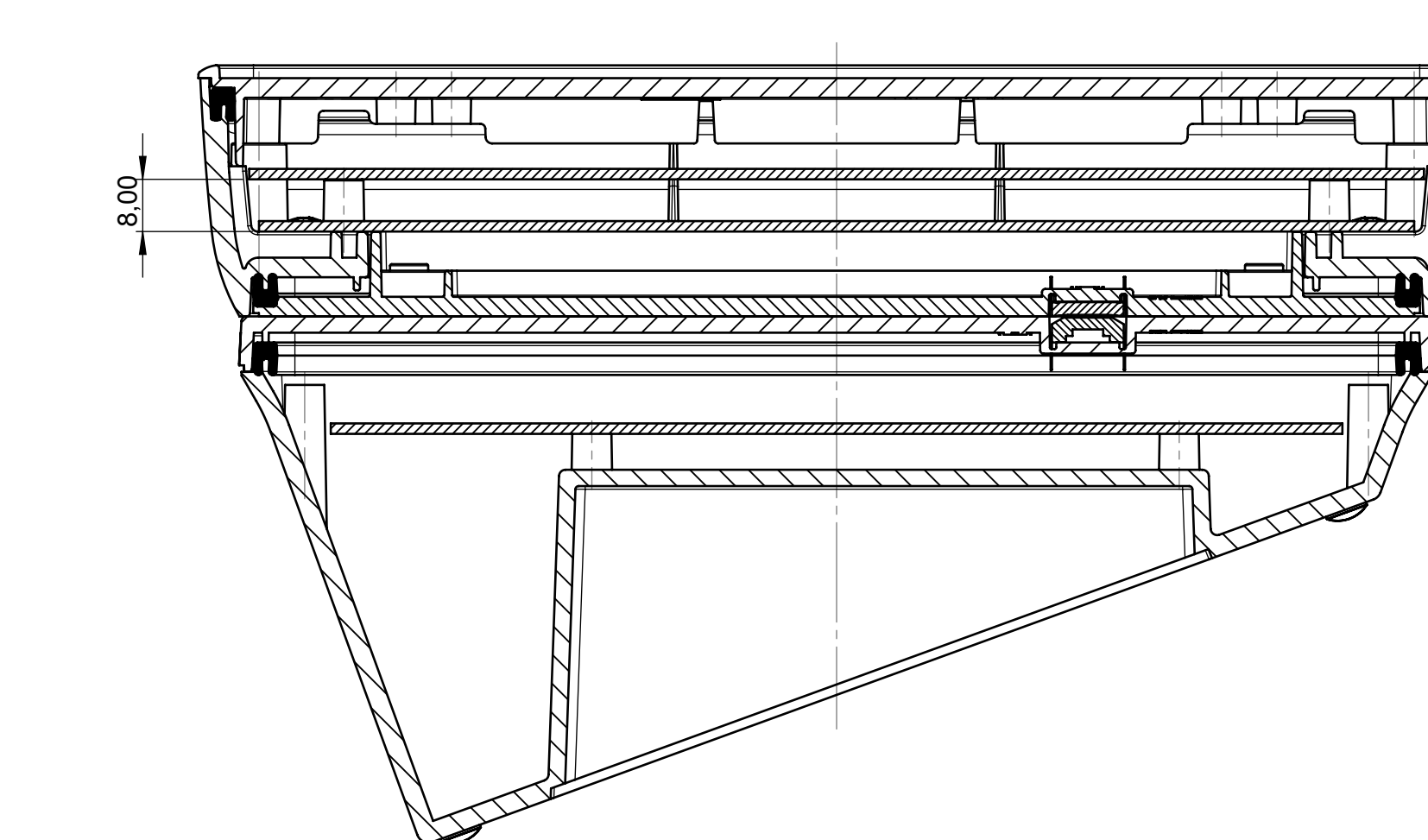

Platine Sockel  
PCB base

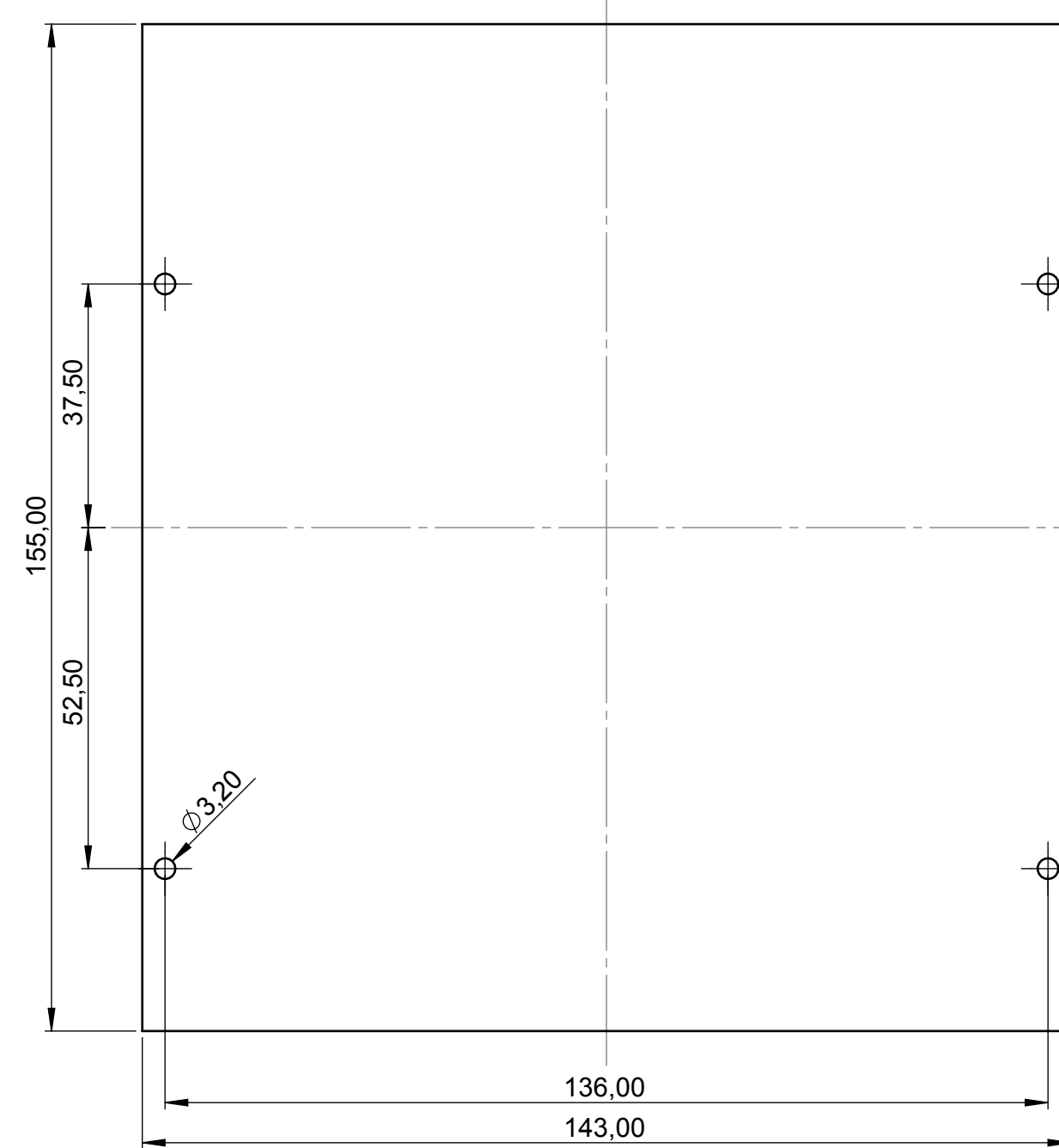

Glaspanel, Bodenplatte mit Rastleiste, Sockel  
Glass panel, bottom panel with snap-in strips, base

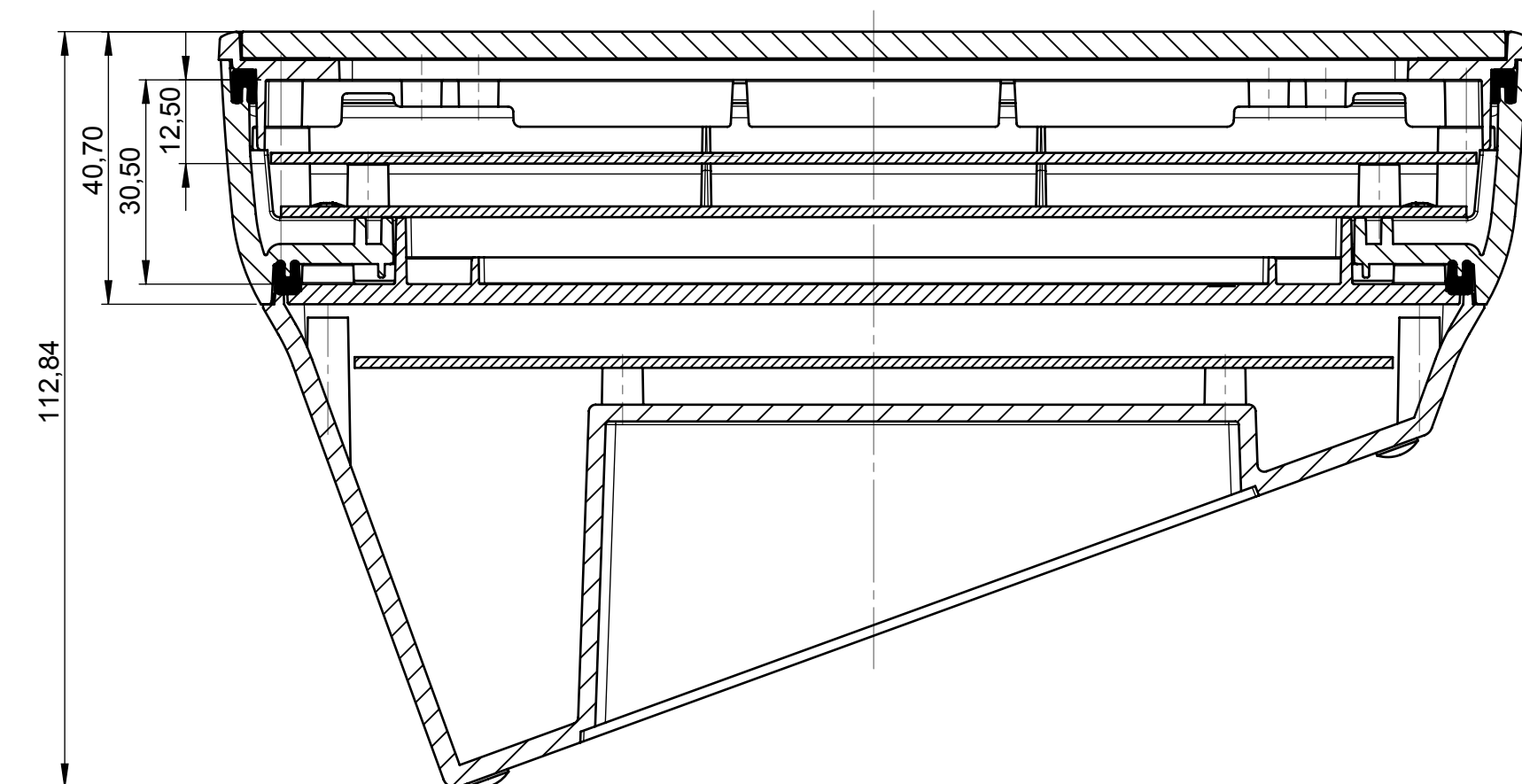

Frontplatte ABS, Bodenplatte mit Rastleiste, Sockel  
Front panel ABS, bottom panel with snap-in strips, base

