

Schnitt B-B
Section B-B

Ansicht "Z"
View "Z"

Platine Oberteil
P C B Top Part

Platine Unterteil
P C B Bottom Part

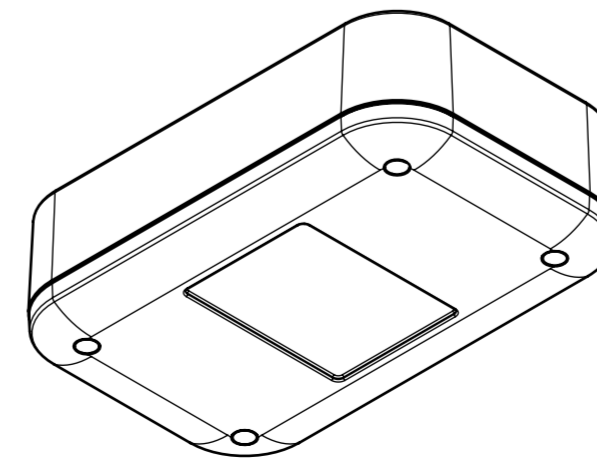
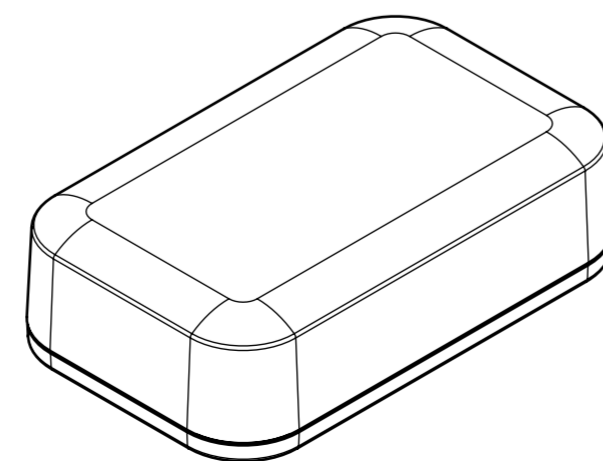
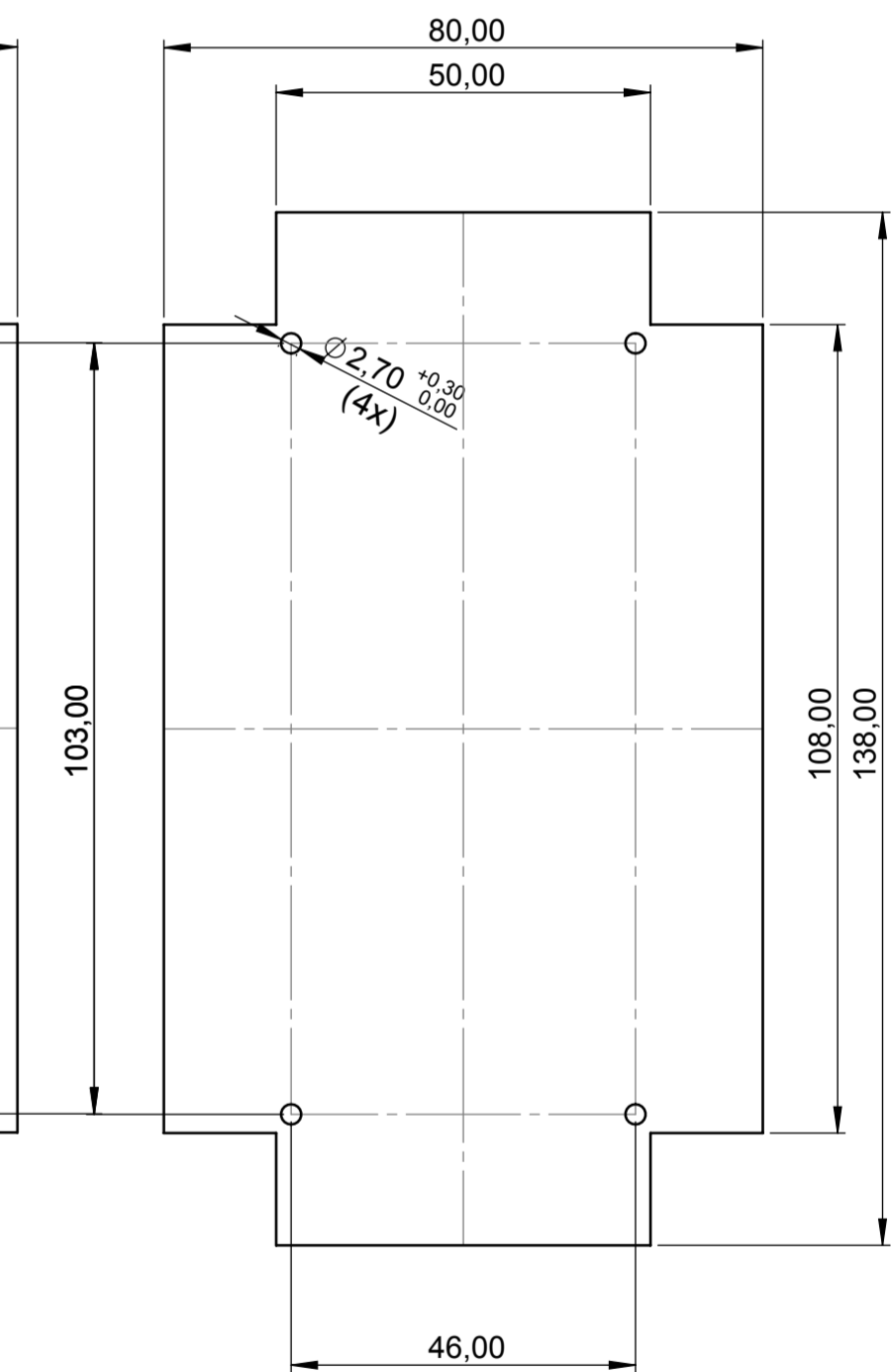
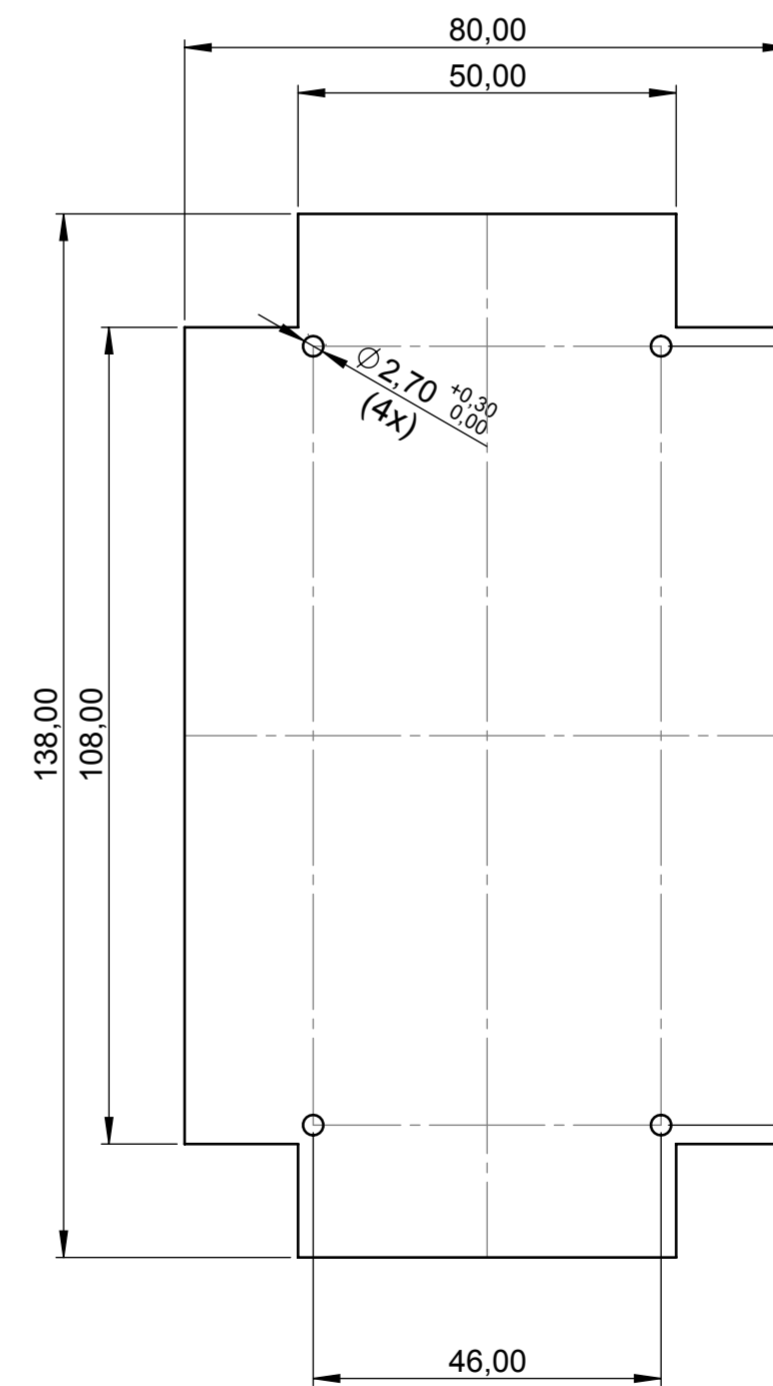
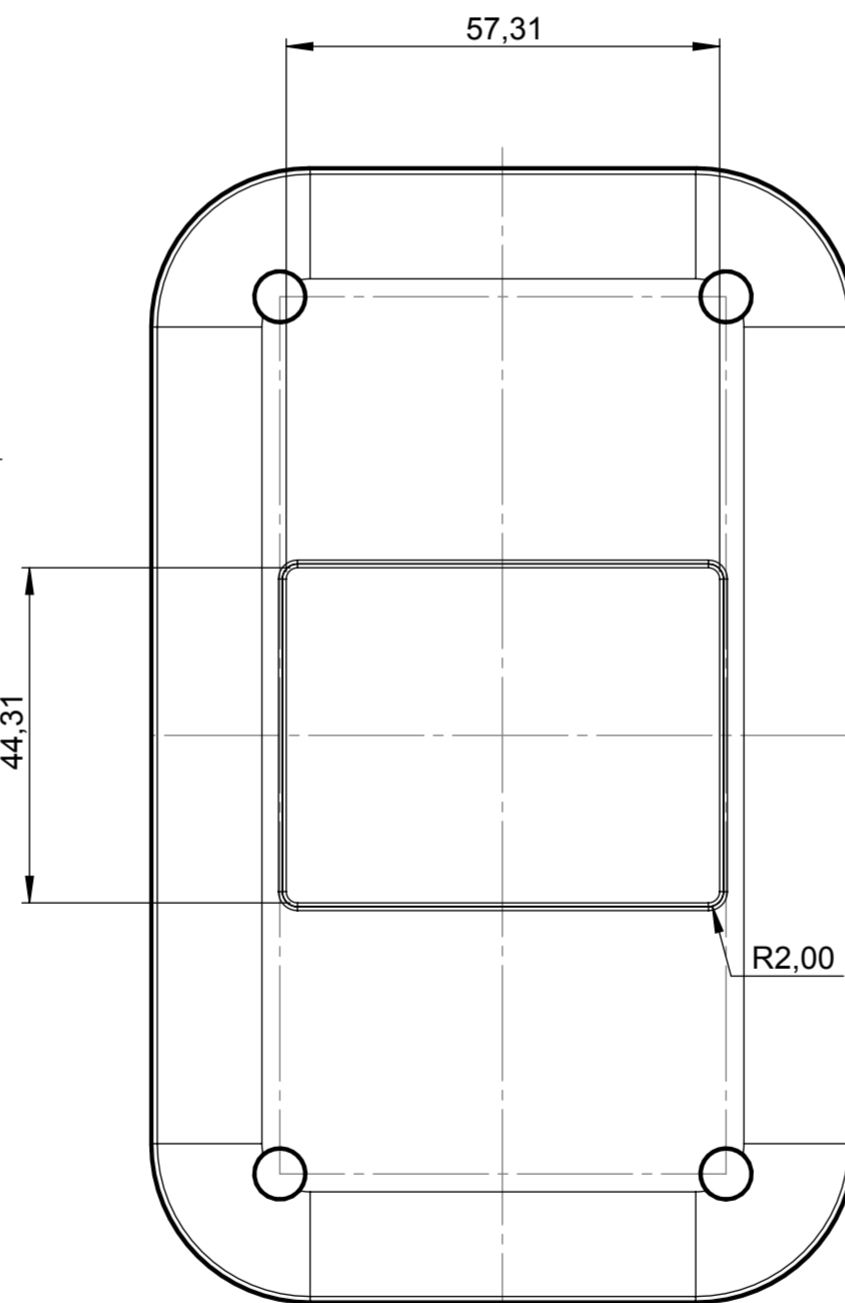
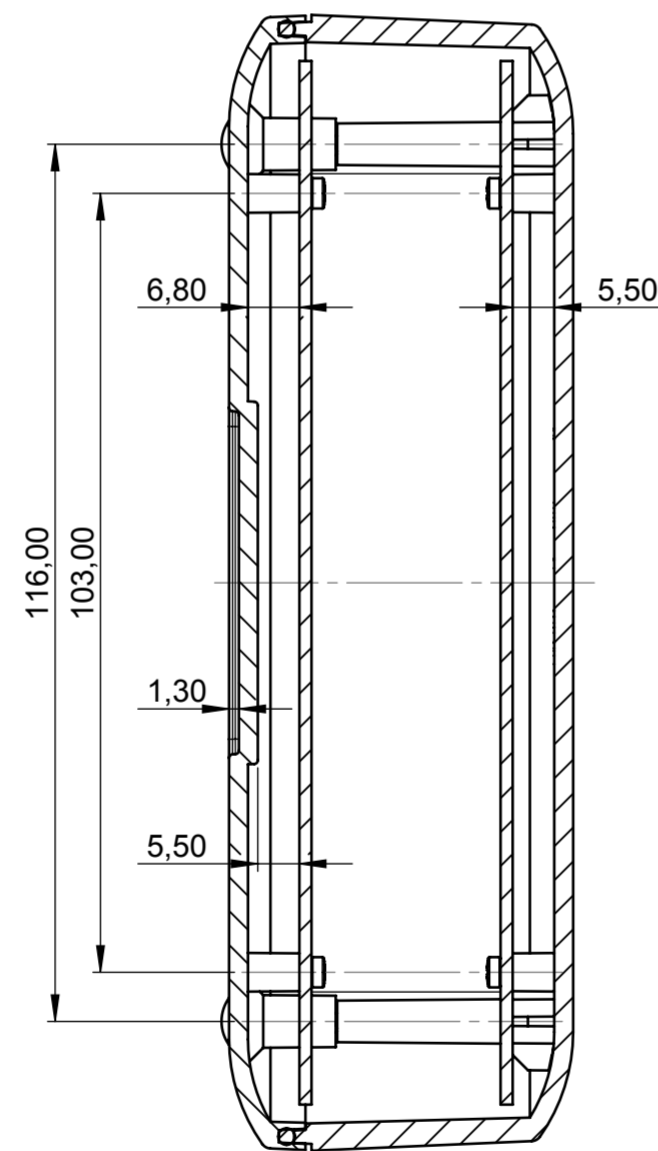
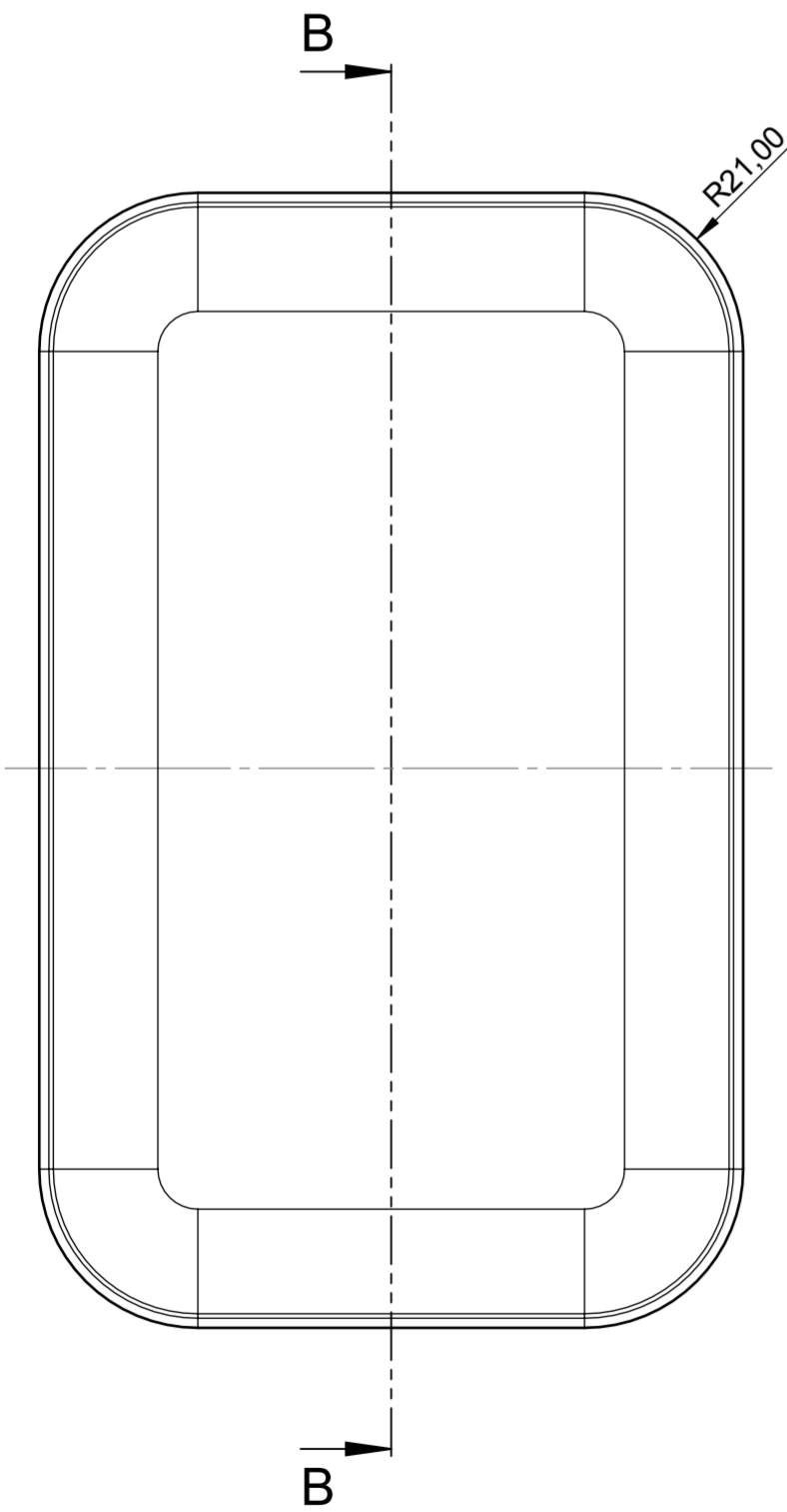

Erst. am: 24.04.2017	Toleranzen: DIN 16742 TG 6	Status: ENTWICKLUNG	
Erst. von: O. Herrlich	Volumen:	Zeichnungsart: KUNDE	
Freig. am:	This document contains proprietary information of OKW Gehäusesysteme GmbH and is tendered subject to the conditions that the information be retained in confidence not be reproduced or copied and not be used or incorporated in any product.		
Freig. von:			
Revision: 01	EVOTEC 150 Ausführung I H (Gehäuse hoch) A9443107		M 1:1
Für dieses Dokument behalten wir uns alle Urheberrechte vor. Es darf auch auszugsweise weder vervielfältigt noch Dritten in irgendeiner Form zugänglich gemacht werden.			Dateiname: 00022698